



brother

Quick Reference Guide

Kurzanleitung

Guide de référence rapide

Beknopte bedieningshandleiding

Guida di riferimento rapido

Guía de referencia rápida

Guia de referència rápida

Краткий справочник

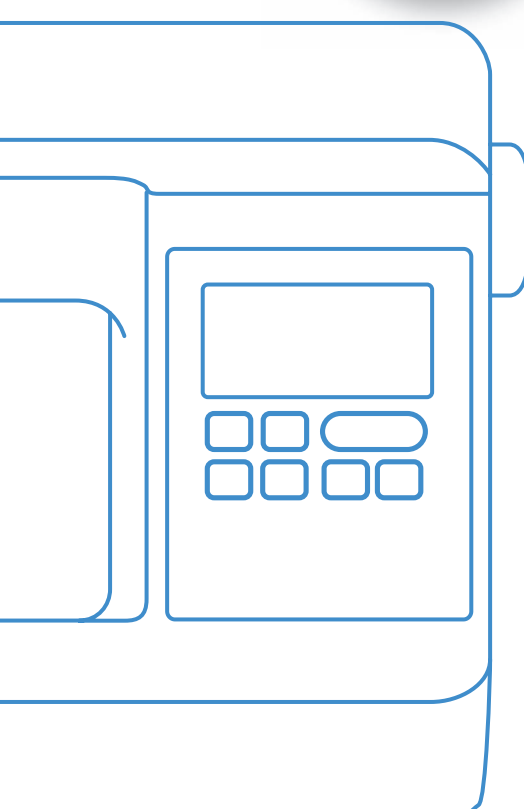

Be sure to read this document before using the machine.
We recommend that you keep this document nearby for future reference.

Lesen Sie dieses Dokument, bevor Sie die Maschine verwenden.
Es wird empfohlen, dieses Dokument griffbereit aufzubewahren, damit Sie jederzeit darin nachschlagen können.

Veillez à lire ce document avant d'utiliser la machine.
Nous vous conseillons de conserver ce document à portée de main pour vous y référer ultérieurement.

Lees dit document voordat u de machine gebruikt.
Houd dit document bij de hand, zodat u het kunt raadplegen.

Leggere questo documento prima di utilizzare la macchina.
Si consiglia di conservare questo documento a portata di mano per un eventuale riferimento futuro.

Lea este documento antes de utilizar la máquina.
Recomendamos que tenga este documento a mano por si necesita consultarlo más adelante.

Certifique-se de ler este documento antes de utilizar a máquina.
Recomendamos guardar este documento em um lugar de fácil acesso para futuras referências.

Обязательно прочитайте этот документ перед началом работы на машине!
Рекомендуется хранить данный документ в удобном месте, чтобы он был доступен для справок.

Before using your machine for the first time please read the “IMPORTANT SAFETY INSTRUCTIONS” in the Operation Manual.

Refer to the Operation Manual for detailed instructions.

In this guide, English screens are used for basic explanations.

For details on the built-in embroidery patterns, refer to the Embroidery Design Guide.

Bevor Sie die Maschine zum ersten Mal verwenden, lesen Sie bitte „WICHTIGE SICHERHEITSHINWEISE“ in der Bedienungsanleitung.

Ausführliche Hinweise finden Sie in der Bedienungsanleitung.

In dieser Anleitung werden für die grundlegenden Erläuterungen englischsprachige Bildschirme verwendet.

Weitere Informationen zu den internen Stickmustern finden Sie in dem Stickmuster-Katalog.

Avant d'utiliser votre machine pour la première fois, veuillez lire les « INSTRUCTIONS DE SÉCURITÉ IMPORTANTES » indiquées dans le manuel d'instructions.

Reportez-vous au manuel d'instructions pour des informations détaillées.

Les écrans de ce guide sont en Anglais pour les explications de base.

Pour plus de détails sur les motifs de broderie intégrés, consultez le guide de motifs de broderie.

Lees – voordat u de machine de eerste keer gebruikt – de “BELANGRIJKE VEILIGHEIDSINSTRUCTIES” in de Bedieningshandleiding.

In de bedieningshandleiding vindt u uitvoerige aanwijzingen.

In deze gids worden Engelse schermen gebruikt bij de uitleg van basisbewerkingen.

Meer bijzonderheden over de ingebouwde borduurpatronen vindt u in de Borduurontwerpen bedieningshandleiding.

Prima di utilizzare la macchina per la prima volta, leggere “IMPORTANTI ISTRUZIONI DI SICUREZZA” nel manuale d'istruzione.

Per le istruzioni dettagliate, consultare il manuale di istruzioni.

Nella presente guida si utilizzano le schermate in inglese per le spiegazioni di base.

Per i dettagli sui motivi da ricamo incorporati, consultare la Guida ai ricami.

Antes de utilizar la máquina por primera vez, lea las “INSTRUCCIONES DE SEGURIDAD IMPORTANTES” en el Manual de instrucciones.

Consulte las instrucciones detalladas en el manual de instrucciones.

En esta guía, para las explicaciones básicas se utilizan pantallas en inglés.

Para más detalles acerca de los patrones de bordado embutidos, consulte la Guía de diseños de bordado.

Antes de utilizar a sua máquina pela primeira vez, leia as “INSTRUÇÕES DE SEGURANÇA IMPORTANTES” no Manual de Operações.

Consulte o manual de operações para obter instruções detalhadas.

Neste manual, as telas em inglês são usadas para as explicações básicas.

Para obter detalhes sobre os padrões de bordado incluídos, consulte o Guia de desenhos de bordado.

Перед первым использованием машины прочитайте раздел “ВАЖНЫЕ ИНСТРУКЦИИ ПО БЕЗОПАСНОСТИ” в Руководстве пользователя.

Подробные инструкции см. в руководстве пользователя.

В данном руководстве в качестве иллюстраций используются англоязычные экраны.

Подробная информация о встроенных рисунках для вышивания приведена в Руководстве по дизайнам для вышивания.

Contents

| |
|---|
| Wireless Network Connection Functions 3 |
| ◆ Operations available with a wireless network connection ... 3 |
| ◆ Wireless network connection 4 |
| Winding/Installing the Bobbin 7 |
| Upper Threading 9 |
| Selecting and Sewing Stitches 11 |
| ◆ Utility Stitches 11 |
| ◆ Decorative Stitches 12 |
| ◆ Character stitches 12 |
| Summary of Stitch Patterns 13 |
| ◆ Utility Stitches 13 |
| ◆ Decorative Stitches 14 |
| ◆ Character stitches 15 |
| Preparing to Embroider 21 |
| Selecting Embroidery Patterns 23 |

Table des matières

| |
|--|
| Fonctions de connexion au réseau sans fil 3 |
| ◆ Opérations disponibles avec une connexion au réseau sans fil ... 3 |
| ◆ Connexion au réseau sans fil 4 |
| Bobinage/installation de la canette 7 |
| Enfilage supérieur 9 |
| Sélection et couture de points 11 |
| ◆ Points utilitaires 11 |
| ◆ Points décoratifs 12 |
| ◆ Points de caractères 12 |
| Sommaire des motifs de point 13 |
| ◆ Points utilitaires 13 |
| ◆ Points décoratifs 14 |
| ◆ Points de caractères 15 |
| Préparation de la broderie 21 |
| Sélection des motifs de broderie 23 |

Sommario

| |
|---|
| Funzioni di connessione di rete wireless 3 |
| ◆ Operazioni disponibili con una connessione di rete wireless ... 3 |
| ◆ Connessione di rete wireless 4 |
| Avvolgimento/Installazione della spolina 7 |
| Infilatura superiore 9 |
| Selezione e cucitura dei vari tipi di punto 11 |
| ◆ Punti utili 11 |
| ◆ Punti decorativi 12 |
| ◆ Punti a caratteri 12 |
| Sommario dei punti 13 |
| ◆ Punti utili 13 |
| ◆ Punti decorativi 14 |
| ◆ Punti a caratteri 15 |
| Preparativi per il ricamo 21 |
| Come selezionare i ricami 23 |

Índice

| |
|---|
| Funções de conexão de rede sem fio 3 |
| ◆ Operações disponíveis por meio de uma conexão de rede sem fio ... 3 |
| ◆ Conexão de rede sem fio 4 |
| Encher/Instalar a bobina 7 |
| Passagem da linha superior 9 |
| Selecionar e costurar pontos 11 |
| ◆ Pontos úteis 11 |
| ◆ Pontos decorativos 12 |
| ◆ Pontos de caracteres 12 |
| Resumo dos padrões de ponto 13 |
| ◆ Pontos úteis 13 |
| ◆ Pontos decorativos 14 |
| ◆ Pontos de caracteres 15 |
| Preparação para bordar 21 |
| Seleção de padrões de bordado 23 |

Inhalt

| |
|--|
| Funktionen zur Verbindung mit dem Wireless-LAN ... 3 |
| ◆ Verfügbare Funktionen bei einer Wireless-LAN-Verbindung... 3 |
| ◆ Verbindung per Wireless-LAN 4 |
| Aufspulen/Einsetzen der Spule 7 |
| Einfädeln des Oberfadens 9 |
| Auswählen und Nähen von Stichen 11 |
| ◆ Nutzstiche 11 |
| ◆ Dekorstiche 12 |
| ◆ Buchstabenstiche 12 |
| Stich-Übersicht 13 |
| ◆ Nutzstiche 13 |
| ◆ Dekorstiche 14 |
| ◆ Buchstabenstiche 15 |
| Vorbereitung zum Sticken 21 |
| Auswählen von Stickmustern 23 |

Inhoudsopgave

| |
|--|
| Functies voor draadloze netwerkverbinding 3 |
| ◆ Functie mogelijkheden met een draadloze netwerkverbinding... 3 |
| ◆ Draadloze netwerkverbinding 4 |
| Spoel opwinden/installeren 7 |
| Inrijgen van de bovendraad 9 |
| Steken selecteren en naaien 11 |
| ◆ Naaisteken 11 |
| ◆ Decoratieve steken 12 |
| ◆ Lettersteken 12 |
| Steken overzicht 13 |
| ◆ Naaisteken 13 |
| ◆ Decoratieve steken 14 |
| ◆ Lettersteken 15 |
| Vorbereidingen voor borduren 21 |
| Borduurpatronen selecteren 23 |

Contenido

| |
|--|
| Funciones de conexión de red inalámbrica 3 |
| ◆ Operaciones disponibles con una conexión de red inalámbrica... 3 |
| ◆ Conexión de red inalámbrica 4 |
| Devanar/colocar la bobina 7 |
| Hilo superior 9 |
| Seleccionar y coser puntadas 11 |
| ◆ Puntadas de utilidad 11 |
| ◆ Puntadas decorativas 12 |
| ◆ Puntadas de carácter 12 |
| Resumen de tipos de puntada 13 |
| ◆ Puntadas de utilidad 13 |
| ◆ Puntadas decorativas 14 |
| ◆ Puntadas de carácter 15 |
| Preparativos para bordar 21 |
| Seleccionar patrones de bordado 23 |

Содержание

| |
|---|
| Функции подключения к беспроводной сети 3 |
| ◆ Операции, доступные при подключении к беспроводной сети ... 3 |
| ◆ Подключение к беспроводной сети 4 |
| Намотка/установка шпульки 7 |
| Заправка верхней нити 9 |
| Выбор и выполнение строчек 11 |
| ◆ Основные строчки 11 |
| ◆ Декоративные строчки 12 |
| ◆ Символьные строчки 12 |
| Схемы строчек 13 |
| ◆ Основные строчки 13 |
| ◆ Декоративные строчки 14 |
| ◆ Символьные строчки 15 |
| Подготовка к вышиванию 21 |
| Выбор рисунков для вышивания 23 |



Wireless Network Connection Functions

Funktionen zur Verbindung mit dem Wireless-LAN

Fonctions de connexion au réseau sans fil

Functies voor draadloze netwerkverbinding

Funzioni di connessione di rete wireless

Funciones de conexión de red inalámbrica

Funções de conexão de rede sem fio

Функции подключения к беспроводной сети

- ◆ Operations available with a wireless network connection
- ◆ Opérations disponibles avec une connexion au réseau sans fil
- ◆ Operazioni disponibili con una connessione di rete wireless
- ◆ Operações disponíveis por meio de uma conexão de rede sem fio
- ◆ Verfügbare Funktionen bei einer Wireless-LAN-Verbindung
- ◆ Functie mogelijkheden met een draadloze netwerkverbinding
- ◆ Operaciones disponibles con una conexión de red inalámbrica
- ◆ Операции, доступные при подключении к беспроводной сети

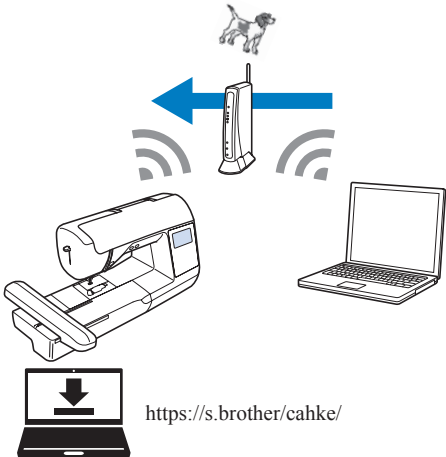
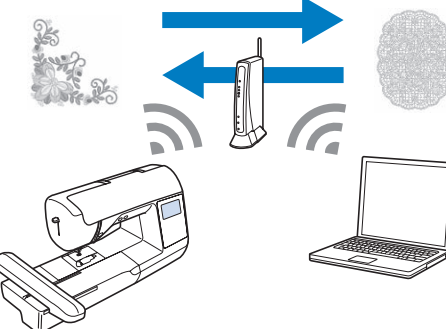
| | | |
|---|--|---|
|  <p>https://s.brother/cahke/</p> | <p>Wirelessly transfer an embroidery pattern from your computer to the machine by using the dedicated Windows application (Design Database Transfer).</p> <p>Utilisez une connexion sans fil pour transférer un motif de broderie de votre ordinateur vers la machine grâce à l'application Windows dédiée (Design Database Transfer (Transfert de Base de données de Motifs)).</p> <p>Trasferimento in modalità wireless dei ricami dal computer alla macchina utilizzando l'apposita applicazione Windows (Design Database Transfer).</p> <p>Faça a transferência sem fio de padrões de bordado do seu computador para a máquina por meio do aplicativo dedicado do Windows (Design Database Transfer).</p> | <p>Übertragen Sie mit Hilfe der speziellen Windows-Anwendung (Design Database Transfer) Stickmuster drahtlos von Ihrem Computer an die Maschine.</p> <p>Breng draadloos een borduurpatroon over van uw computer naar de machine met gebruik van de speciale Windows-toepassing (Design Database Transfer).</p> <p>Transfiera de forma inalámbrica un patrón de bordado desde el ordenador a la máquina utilizando la aplicación específica de Windows (Design Database Transfer).</p> <p>Беспроводная передача дизайна вышивания с компьютера на машину с помощью специального приложения для Windows (Design Database Transfer).</p> |
|  | <p>Wirelessly transfer to the machine an embroidery pattern edited with embroidery editing software (PE-DESIGN version 11 or later) on a computer. Also, transfer to PE-DESIGN an embroidery pattern edited on the machine.</p> <p>Utilisez une connexion sans fil pour transférer vers la machine un motif de broderie modifié avec le logiciel d'édition de broderie (PE-DESIGN version 11 ou ultérieure) sur un ordinateur. Transférez également vers PE-DESIGN un motif de broderie modifié sur la machine.</p> <p>Trasferimento in modalità wireless alla macchina dei ricami modificati con il software (PE-DESIGN versione 11 o successive) sul computer. Inoltre, trasferimento a PE-DESIGN dei ricami modificati sulla macchina.</p> <p>Faça a transferência sem fio para a máquina de padrões de bordado editados em um computador com o software de edição de bordados (PE-DESIGN versão 11 ou posterior). Além disso, transfira padrões de bordado editados na máquina para o PE-DESIGN.</p> | <p>Übertragen Sie drahtlos ein mit einer Stickeditorssoftware (PE-DESIGN Version 11 oder höher) auf einem Computer bearbeitetes Stickmuster an die Maschine. Sie können auch ein auf der Maschine bearbeitetes Stickmuster an PE-DESIGN übertragen.</p> <p>Breng draadloos een borduurpatroon over naar de machine dat is bewerkt in borduurbewerkingssoftware (PE-DESIGN versie 11 of hoger) op een computer. Eveneens is het mogelijk om 'op de machine bewerkte borduurpatronen' over te brengen naar PE-DESIGN.</p> <p>Transfiera de forma inalámbrica a la máquina un patrón de bordado editado con un programa de edición de bordados (PE-DESIGN versión 11 o posterior) en un ordenador. Igualmente, transfiera a PE-DESIGN un patrón de bordado editado en la máquina.</p> <p>Беспроводная передача на машину дизайна вышивания, отредактированного на компьютере в программе редактирования вышивок (PE-DESIGN версии 11 или выше). Также возможна передача в программу PE-DESIGN дизайна вышивания, отредактированного на машине.</p> |

When an updated version of software is available on our website, the wireless LAN key appears as .

Quand une mise à jour de la version du logiciel est disponible sur notre site Web, la touche du réseau local LAN sans fil apparaît sous la forme .

Quando sul nostro sito Web è disponibile una versione aggiornata del software, il tasto LAN wireless viene visualizzato come .

Quando uma versão atualizada do software está disponível em nosso site, a tecla LAN sem fio aparece como .

Wenn eine aktualisierte Softwareversion auf unserer Website verfügbar ist, wird die Taste „Wireless-LAN“ mit dem Symbol  angezeigt.

Wanneer er een update versie van de software beschikbaar is op onze website, wordt de toets voor WLAN Draadloze verbinding weergegeven als .



Cuando en nuestro sitio web está disponible una versión actualizada del software, la tecla de LAN inalámbrica se muestra como .



Когда на нашем сайте доступна обновленная версия программного обеспечения, кнопка “Беспроводная сеть” имеет вид .



- ◆ Wireless network connection
- ◆ Connexion au réseau sans fil
- ◆ Connessione di rete wireless
- ◆ Conexão de rede sem fio



- ◆ Verbindung per Wireless-LAN
- ◆ Draadloze netwerkverbinding
- ◆ Conexión de red inalámbrica
- ◆ Подключение к беспроводной сети







When you first turn on the machine, the following message about a wireless LAN connection appears.
To set up a connection, touch , and then continue with step .



Quand vous mettez la machine sous tension pour la première fois, le message suivant apparaît, à propos de la connexion au réseau local LAN sans fil.
Pour configurer une connexion, appuyez sur , puis continuez en passant à l'étape .



Quando si accende la macchina per la prima volta, viene visualizzato il seguente messaggio relativo a una connessione LAN wireless.
Per configurare una connessione, toccare  e continuare con il passaggio .

Quando você liga a máquina pela primeira vez, a seguinte mensagem sobre uma conexão de LAN sem fio é exibida.
Para configurar uma conexão, toque em  e continue da etapa .

Beim ersten Einschalten der Maschine wird die folgende Meldung bezüglich einer Verbindung per Wireless-LAN angezeigt.
Tippen Sie auf , um eine Verbindung einzurichten. Befolgen Sie dann Schritt .

Wanneer u de machine de eerste keer aan zet, wordt het volgende bericht over een WLAN Draadloze verbinding weergegeven.
Druk op  als u een verbinding wilt instellen en ga vervolgens door met stap .

Cuando se activa la máquina por primera vez, se muestra el siguiente mensaje acerca de una conexión de LAN inalámbrica.
Para establecer una conexión, toque  y luego continúe con el paso .

При первом включении машины отображается указанное сообщение о подключении к беспроводной сети.
Чтобы настроить подключение, нажмите  и перейдите к пункту .

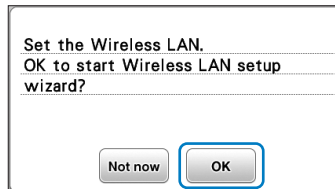

1 Find your security information (SSID and network key) and note it.
Recherchez vos informations de sécurité (SSID et clé réseau) et notez-les.
Cercare le informazioni di sicurezza (nome SSID e chiave di rete) e annotarle.
Encontre e anote suas informações de segurança (SSID e chave de rede).

Suchen Sie Ihre Sicherheitsinformationen (SSID und Netzwerkschlüssel) heraus und notieren Sie sie.
Zoek uw beveiligingsgegevens (SSID en netwerksleutel) op en noteer deze.
Busque su información de seguridad (SSID y clave de red) y anótela.
Найдите данные безопасности своей беспроводной сети (название SSID и сетевой ключ) и запишите их.

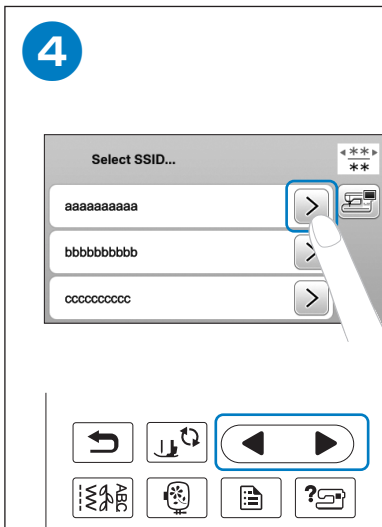
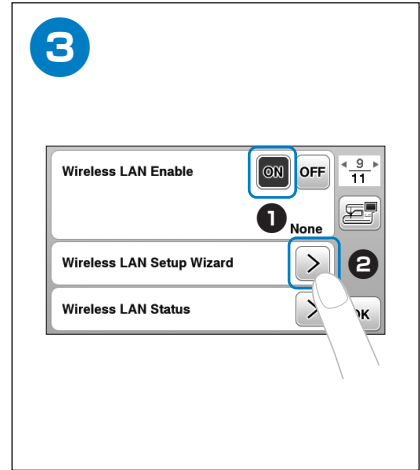
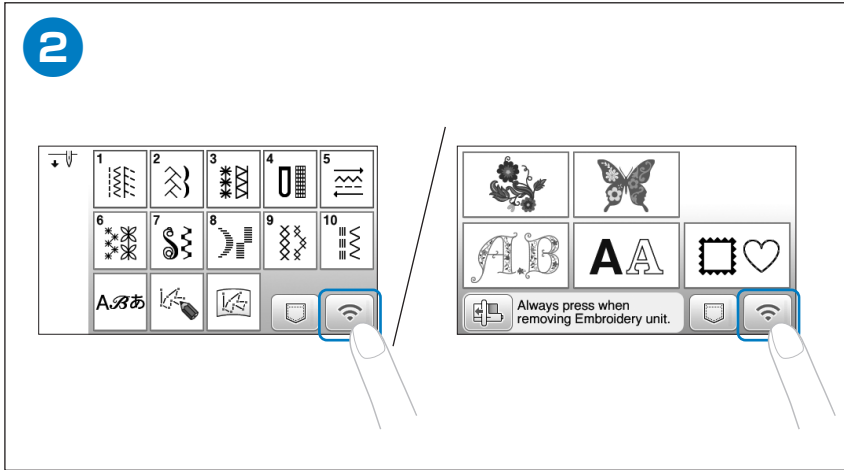

Touch **>** beside the SSID that was noted in step **1**.

- When displaying next or previous pages, touch **<** or **>** key to search the SSID that was noted.

Tippen Sie neben der in Schritt **1** notierten SSID auf **>**.

- Wird eine der nächsten oder vorherigen Seiten angezeigt, tippen Sie auf die Taste **<** oder **>**, um die notierte SSID zu suchen.

Appuyez sur **>** à côté du SSID que vous avez noté lors de l'étape **1**.

- Lorsqu'une page suivante ou précédente est affichée, appuyez sur **<** ou **>** pour chercher le SSID que vous avez noté.

Druk op **>** naast de SSID die u hebt genoteerd in stap **1**.

- Wanneer u een volgende of vorige pagina weergeeft, drukt u op de toets **<** of **>** om te zoeken naar de SSID die u hebt genoteerd.

Toccare **>** accanto all'SSID annotato al passaggio **1**.

- Quando si visualizzano le pagine precedenti o successive, toccare il tasto **<** o **>** per cercare l'SSID precedentemente annotato.

Toque **>** que se muestra junto al SSID que se ha anotado en el paso **1**.

- Cuando se muestren las páginas siguientes o anteriores, toque la tecla **<** o **>** para buscar el SSID que se ha anotado.

Toque em **>** ao lado do SSID anotado na etapa **1**.

- Ao exibir as páginas seguintes ou anteriores, toque na tecla **<** ou **>** para pesquisar o SSID anotado.

Нажмите **>** рядом с именем беспроводной сети (SSID), которое вы записали в пункте **1**.

- Если отображается следующая или предыдущая страница, нажмите **<** или **>** для поиска нужного имени беспроводной сети (SSID).

5

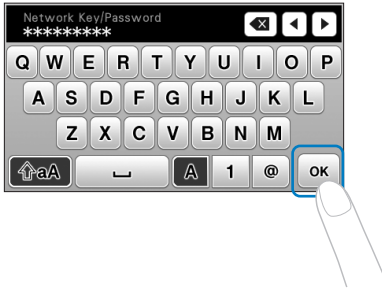

Enter the network key (password) that was noted, and then touch **OK**.

Geben Sie den notierten Netzwerkschlüssel (Passwort) ein und tippen Sie dann auf **OK**.

Saisissez la clé réseau (mot de passe) que vous avez notée, puis appuyez sur **OK**.

Voer de netwerksleutel (wachtwoord) in die u hebt genoteerd en druk vervolgens op **OK**.

Inserire la chiave di rete (password) che è stata annotata e premere **OK**.

Seleccione la clave de red (contraseña) que se ha anotado y toque **OK**.

Inira a chave de rede (senha) anotada e toque em **OK**.

Введите записанный сетевой ключ (пароль) и нажмите **OK**.

6

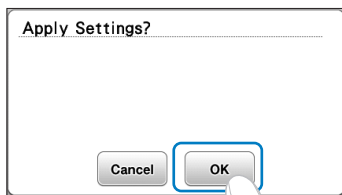

7

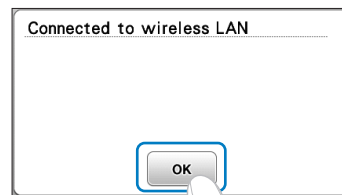

8

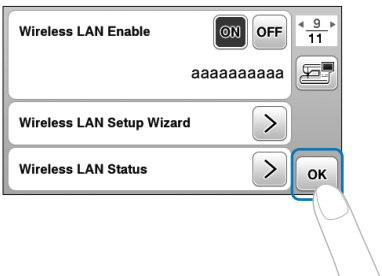

Touch **OK** to exit the setup.

Tippen Sie auf **OK**, um die Einrichtung zu verlassen.

Appuyez sur **OK** pour quitter la procédure de configuration.

Druk op **OK** om de installatie af te sluiten.

Premere **OK** per uscire dalla configurazione.

Toque **OK** para salir de la configuración.

Toque em **OK** para sair da configuração.

Нажмите **OK** для выхода из режима настройки.



Winding/Installing the Bobbin

Aufspulen/Einsetzen der Spule

Bobinage/installation de la canette

Spool opwinden/installeren

Avvolgimento/Installazione della spolina

Devanar/colocar la bobina

Encher/Instalar a bobina

Намотка/установка шпульки

Follow the steps below in numerical order. Refer to the Operation Manual for detailed instructions.
 Führen Sie die folgenden Schritte in der numerischen Reihenfolge aus. Ausführliche Hinweise finden Sie in der Bedienungsanleitung.
 Respectez les étapes ci-dessous, dans l'ordre numérique. Reportez-vous au manuel d'instructions pour des informations détaillées.
 Volg onderstaande stappen in numerieke volgorde. In de bedieningshandleiding vindt u uitvoerige aanwijzingen.
 Seguire i passaggi di seguito, in ordine numerico. Per le istruzioni dettagliate, consultare il manuale di istruzioni.
 Siga los pasos descritos a continuación, en orden numérico. Consulte las instrucciones detalladas en el manual de instrucciones.
 Siga as etapas abaixo, em ordem numérica. Consulte o manual de operações para obter instruções detalhadas.
 Выполните описанные ниже действия по порядку номеров. Подробные инструкции см. в руководстве пользователя.

Use the plastic bobbin that comes with this machine or bobbins of the same type.
 Verwenden Sie die Kunststoffspule, die mit dieser Maschine geliefert wird, oder Spulen vom gleichen Typ.
 Utilisez la canette en plastique fournie avec cette machine ou des canettes du même type.
 Gebruik de plastic spool die is meegeleverd met deze machine of spoulen van hetzelfde type.
 Utilizzare la spolina di plastica in dotazione con la macchina o spoline dello stesso tipo.
 Utilice la bobina de plástico suministrada con esta máquina o bobinas del mismo tipo.
 Use a bobina plástica que acompanha a máquina ou bobinas do mesmo tipo.
 Используйте прилагаемую к машине пластиковую шпульку или шпульки такого же типа.

11,5 mm (approx. 7/16 inch)
 11,5 mm (ca. 7/16 Zoll)
 11,5 mm (env. 7/16" / pouce)
 11,5 mm (ca. 7/16 inch)
 11,5 mm (circa 7/16 inch)
 11,5 mm (aprox. 7/16 pulg.)
 11,5 mm (aprox. 7/16 polegada)
 11,5 mm (прим. 7/16 дюйма)

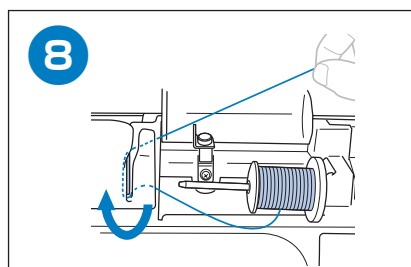
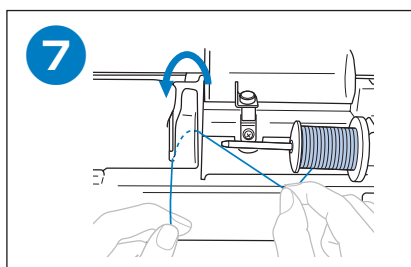
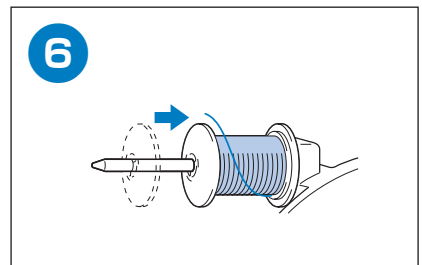
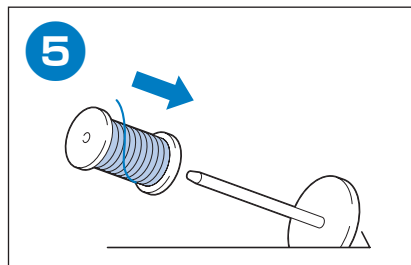
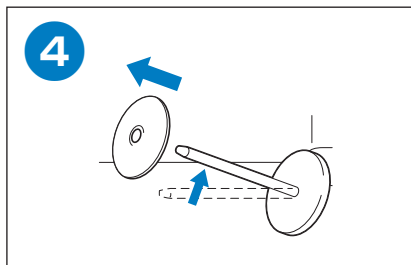
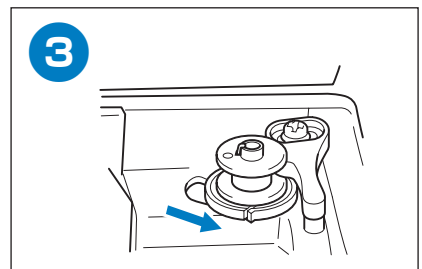
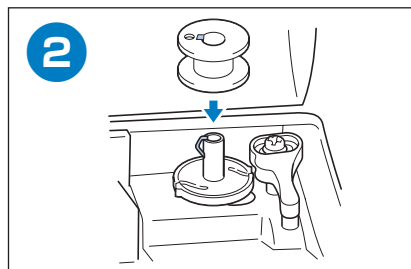
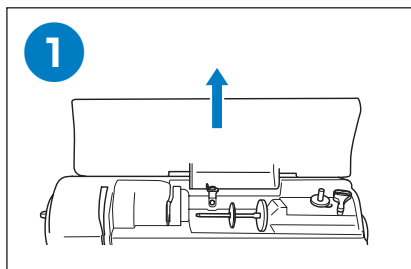
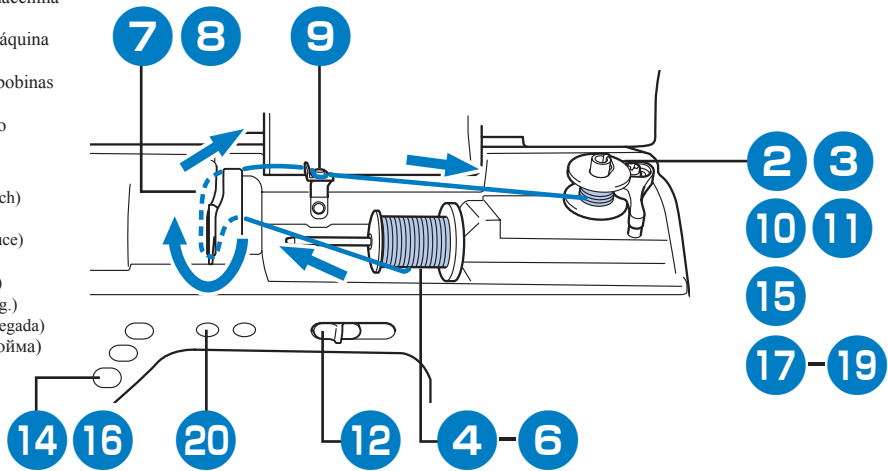

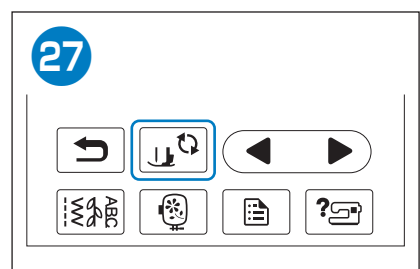
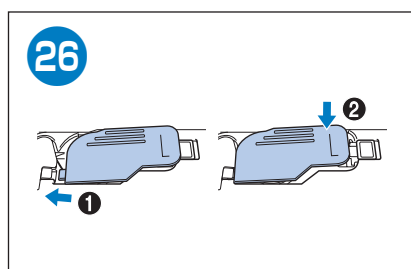
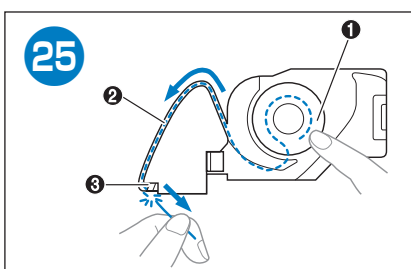
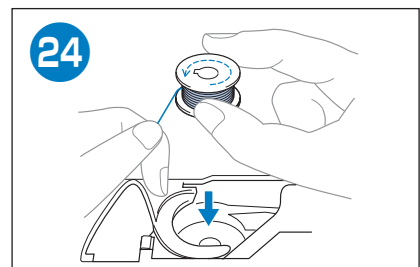
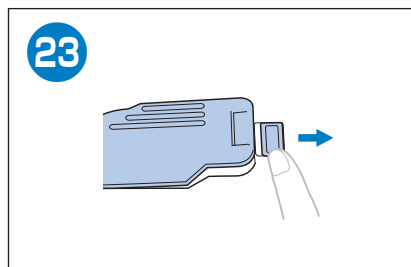
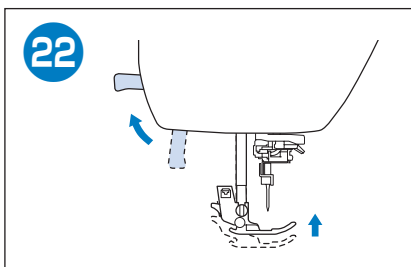
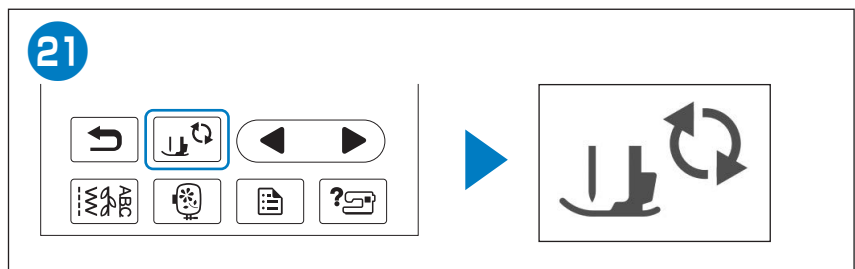
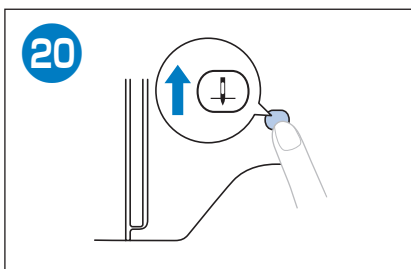
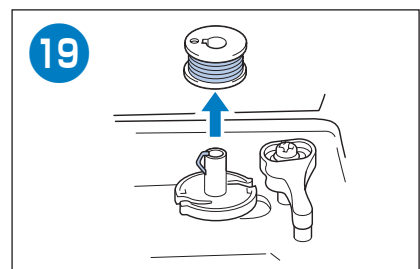
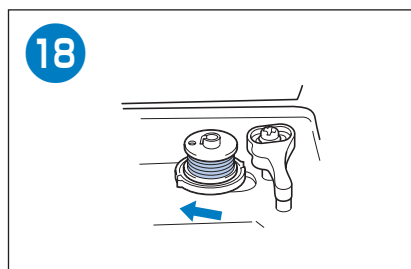
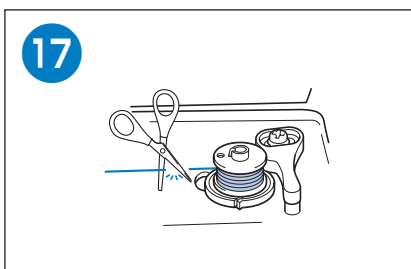
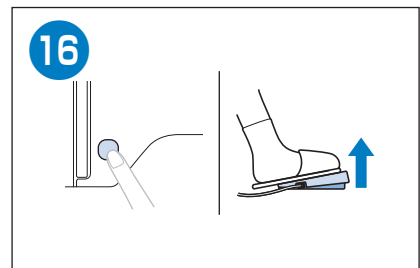
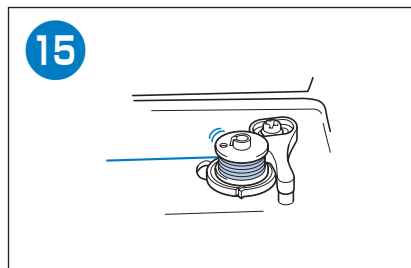
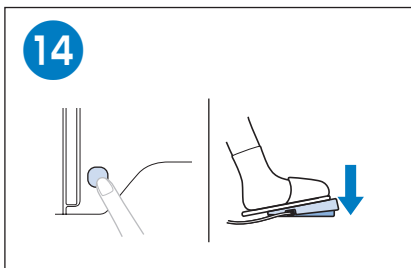
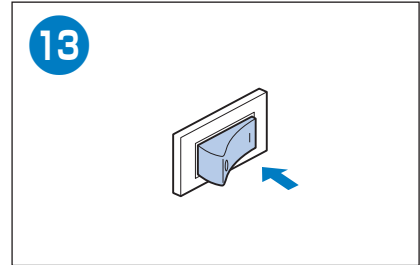
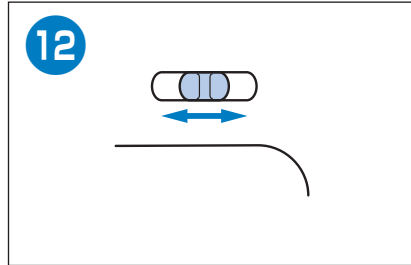
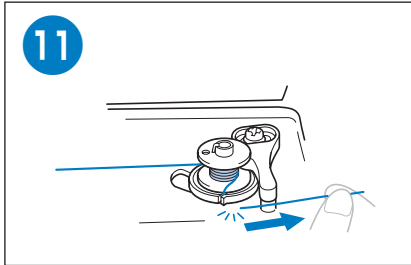
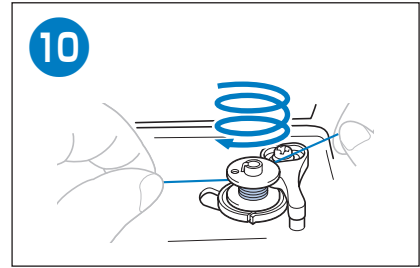
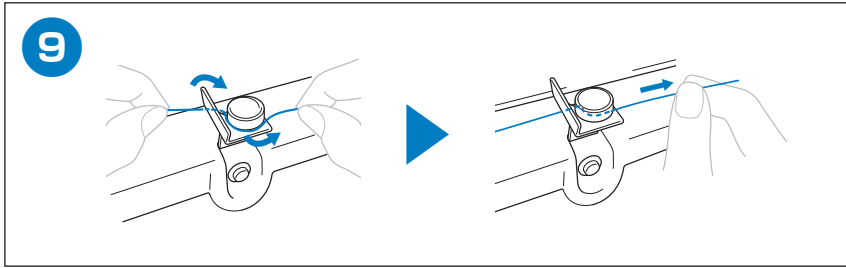



Upper Threading
Einfädeln des Oberfadens
Enfilage supérieur
Inrijgen van de bovendraad
Infilatura superiore
Hilo superior
Passagem da linha superior
Заправка верхней нити

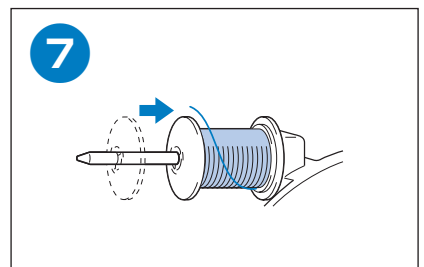
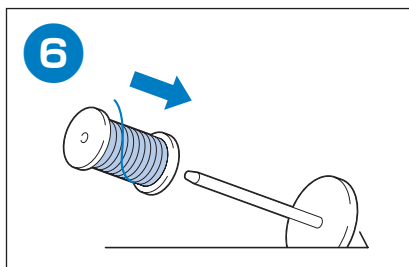
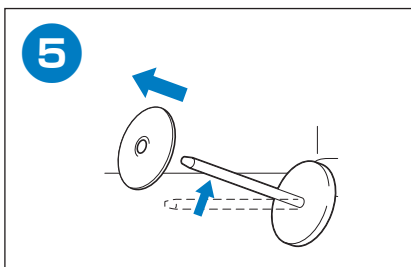
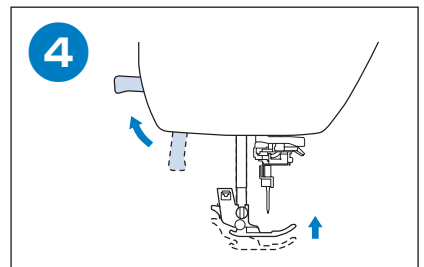
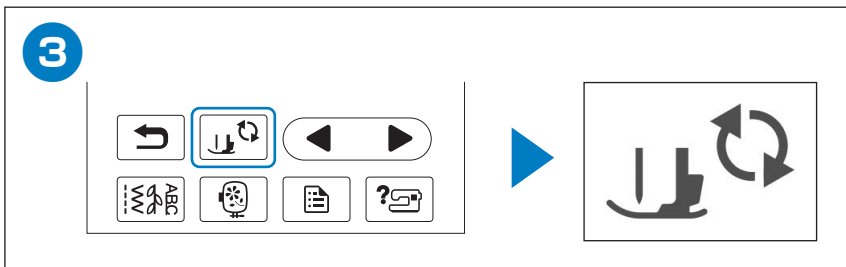
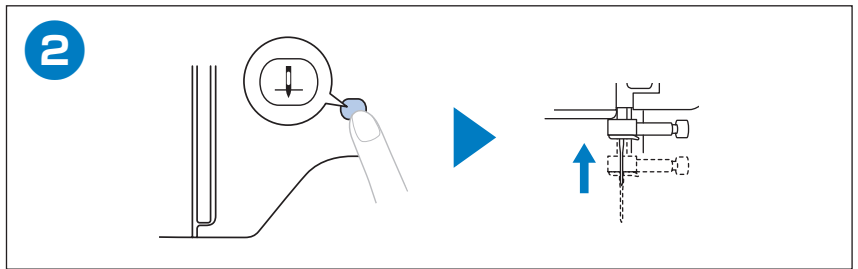
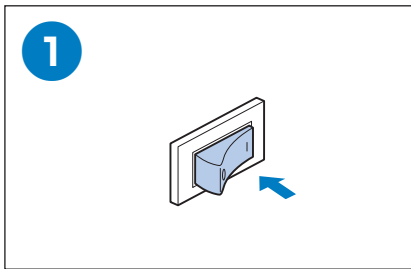
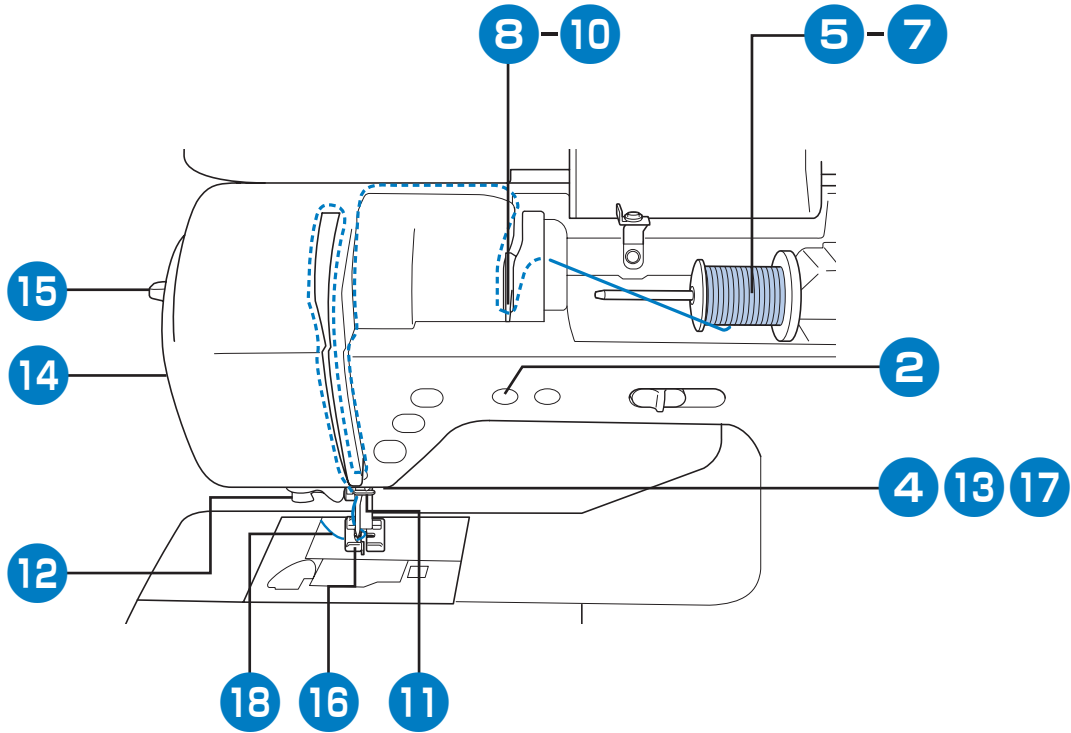

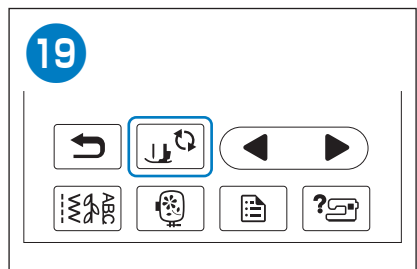
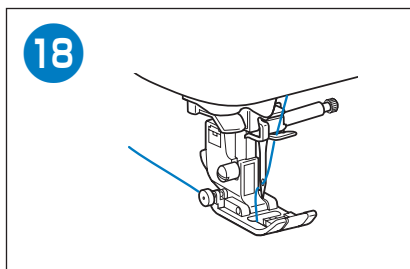
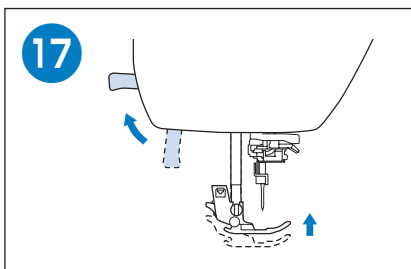
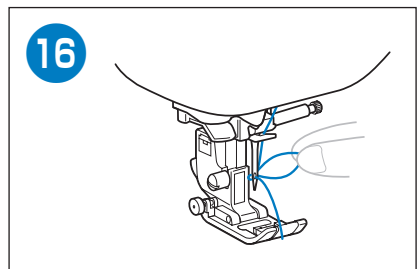
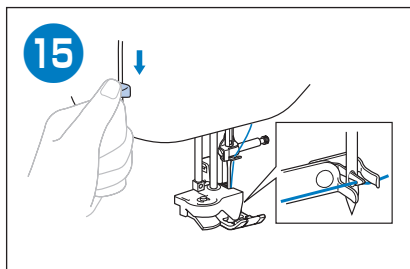
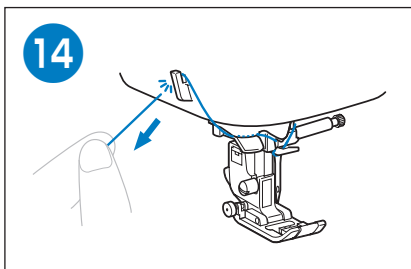
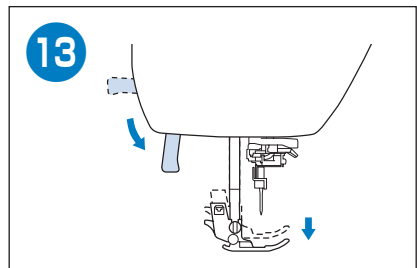
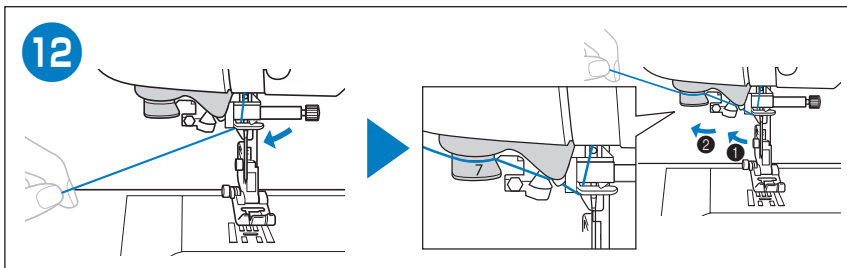
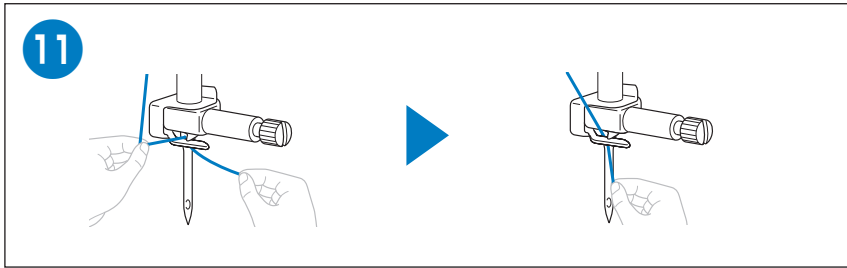
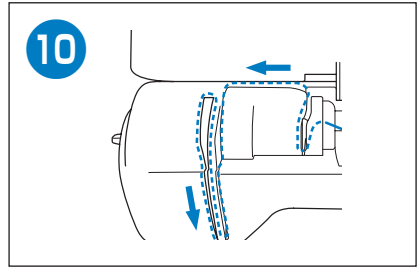
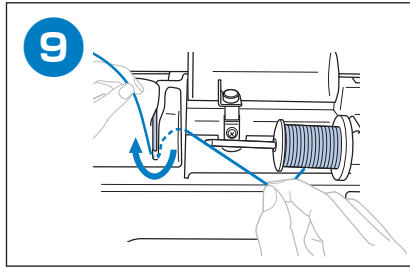
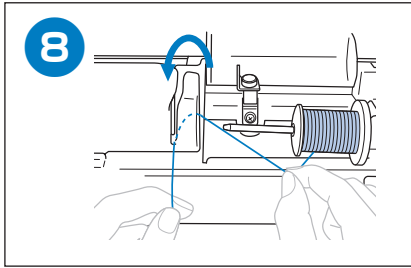

Selecting and Sewing Stitches

Auswählen und Nähen von Stichen

Sélection et couture de points

Steken selecteren en naaien

Selezione e cucitura dei vari tipi di punto

Seleccionar y coser puntadas

Выбор и выполнение строчек

◆ Utility Stitches
◆ Punti utili

◆ Nutzstiche
◆ Puntadas de utilidad

◆ Points utilitaires
◆ Pontos úteis

◆ Naaisteken
◆ Основные строчки

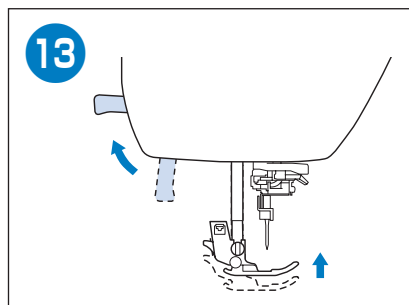
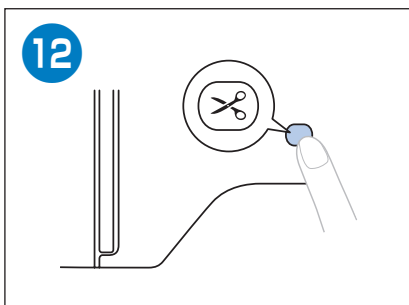
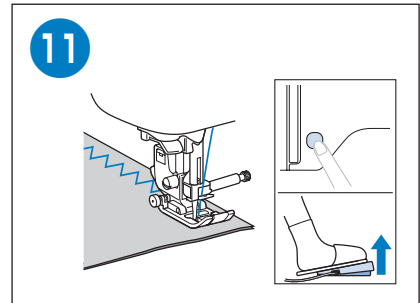
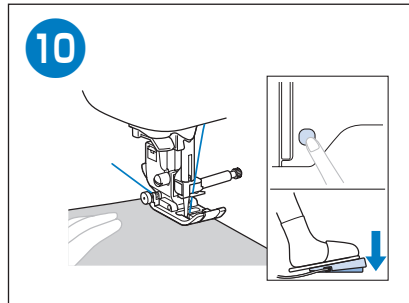
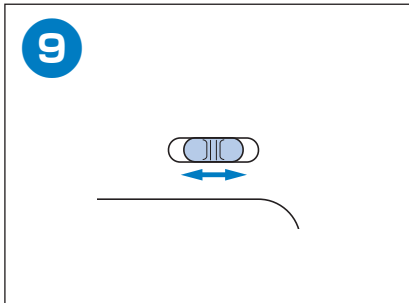
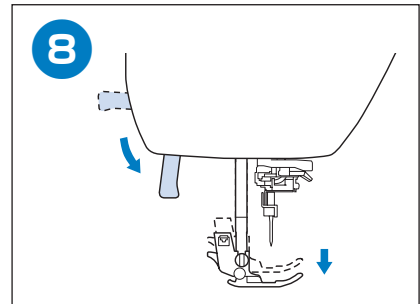
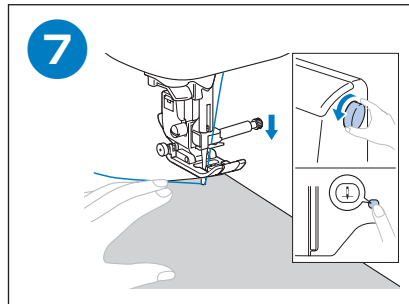
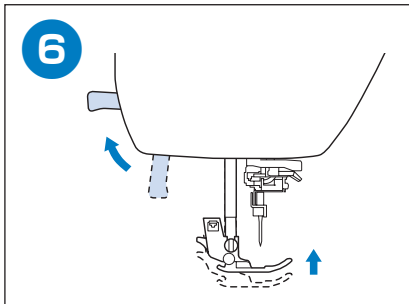
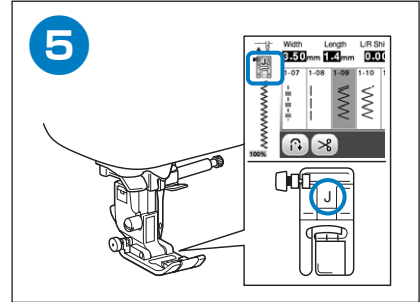
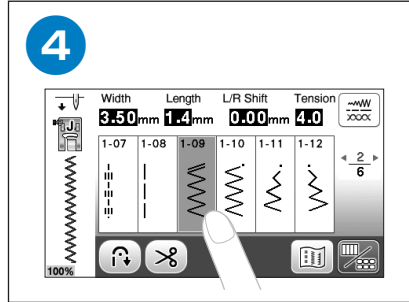
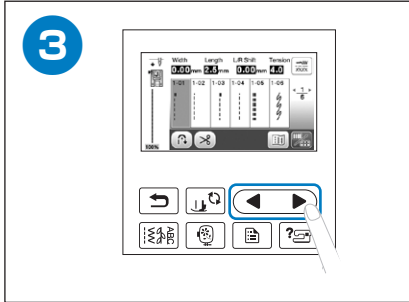
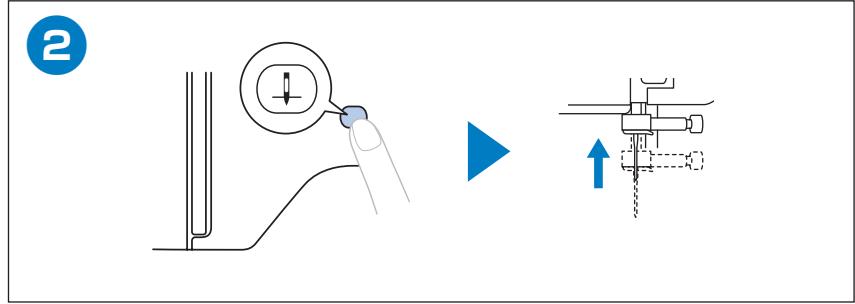
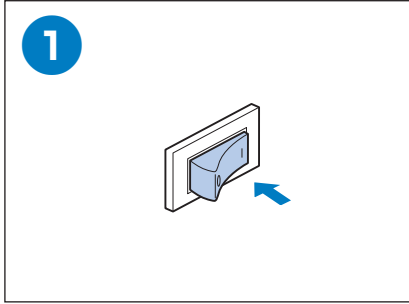

◆ Decorative Stitches ◆ Dekorstiche ◆ Points décoratifs ◆ Decoratieve steken
 ◆ Punt decorativi ◆ Puntadas decorativas ◆ Pontos decorativos ◆ Декоративные строчки

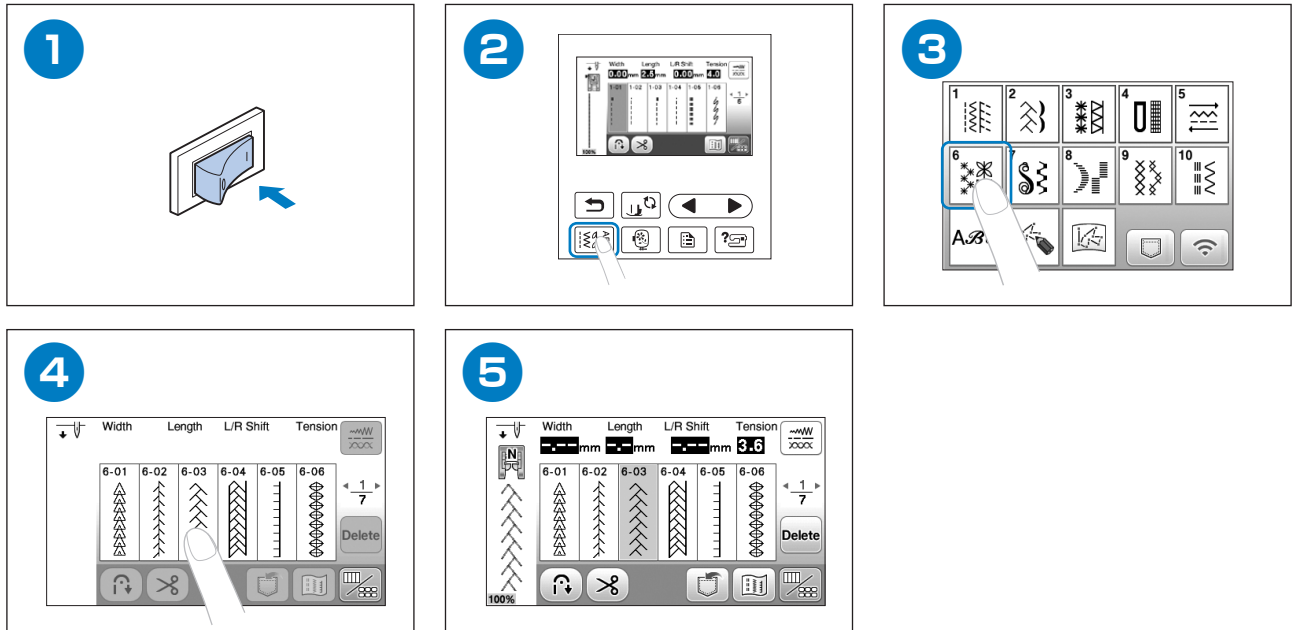

◆ Character stitches ◆ Buchstabenstiche ◆ Points de caractères ◆ Lettersteken
 ◆ Punt a caratteri ◆ Puntadas de carácter ◆ Pontos de caracteres ◆ Символьные строчки

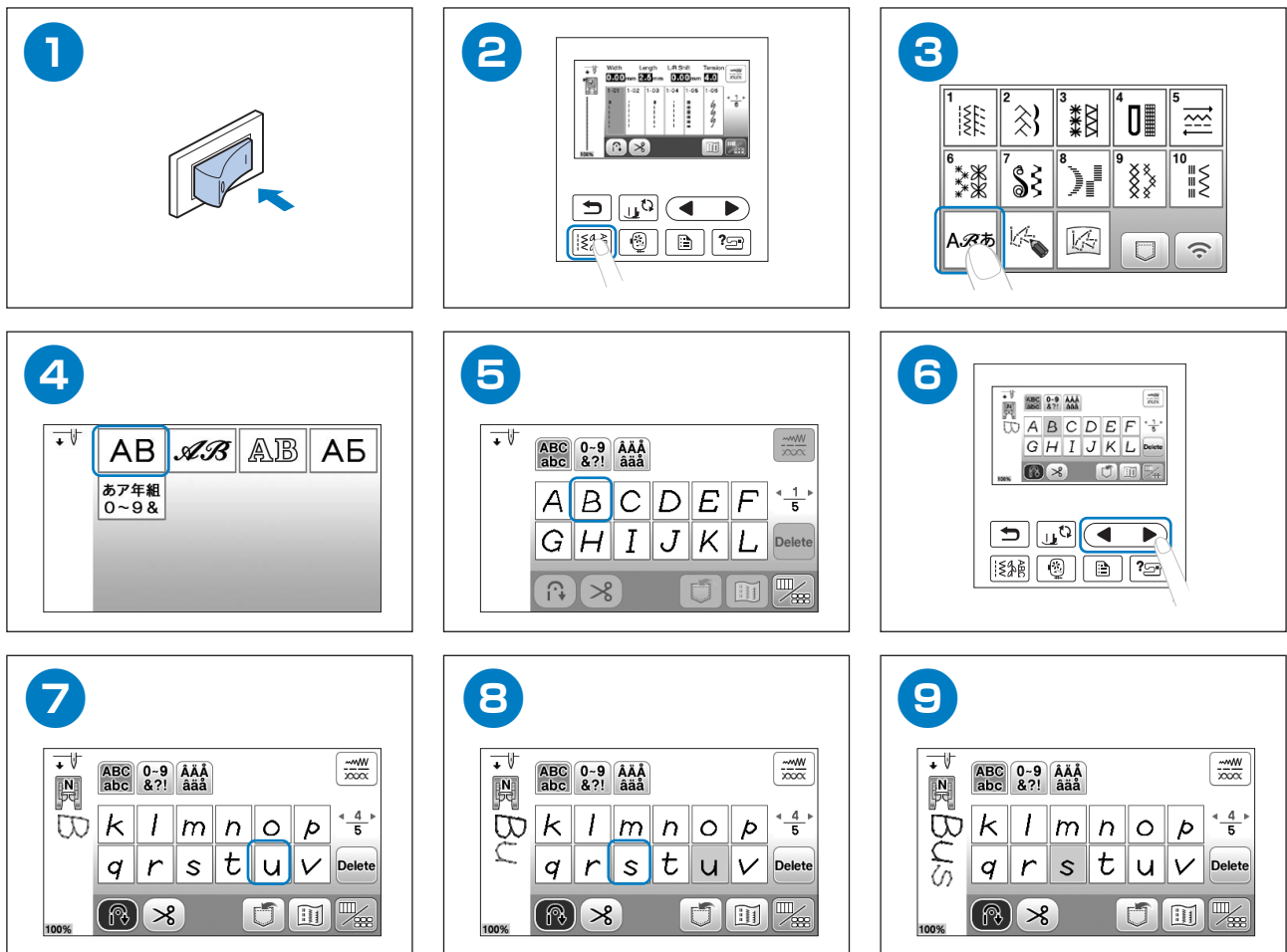



Summary of Stitch Patterns
Stich-Übersicht
Sommaire des motifs de point
Steken overzicht
Sommario dei punti
Resumen de tipos de puntada
Resumo dos padrões de ponto
Схемы строчек

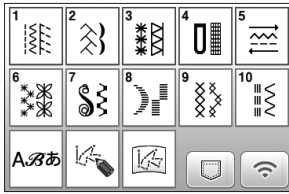

◆ Utility Stitches
 ◆ Punti utili

◆ Nutztstiche
 ◆ Puntadas de utilidad

◆ Points utilitaires
 ◆ Pontos úteis

◆ Naaisteken
 ◆ Основные строчки

• 1-01~1-35

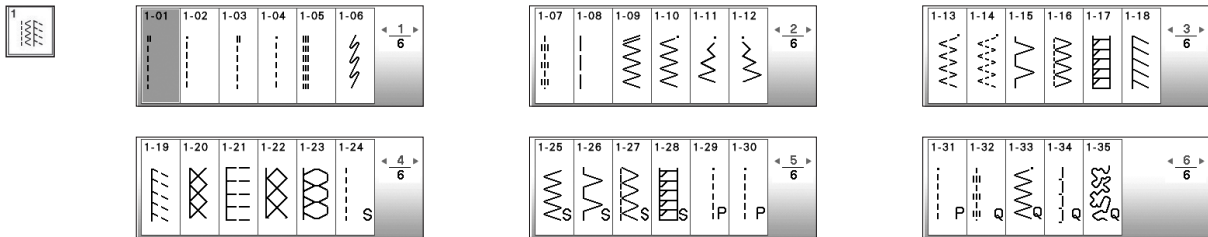

• 2-01~2-20

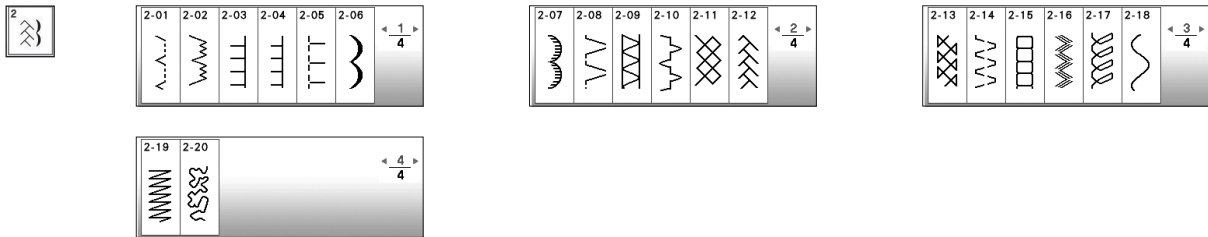

• 3-01~3-22

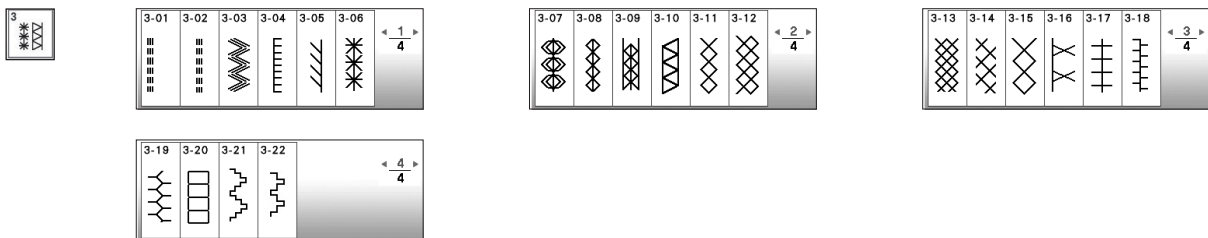

• 4-01~4-15

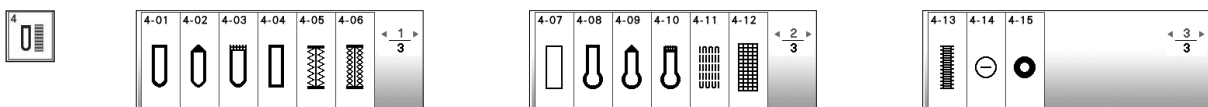

• 5-01~5-08

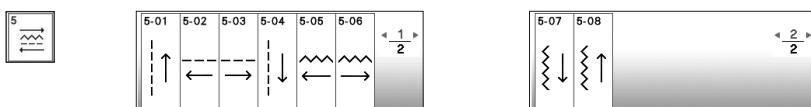

◆ Decorative Stitches
◆ Puntis decorativi

◆ Dekorstiche
◆ Puntadas decorativas

◆ Points décoratifs
◆ Pontos decorativos

◆ Decoratieve steken
◆ Декоративные строчки

• 6-01~6-40

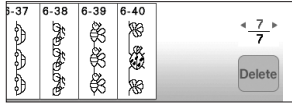
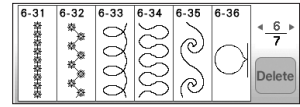
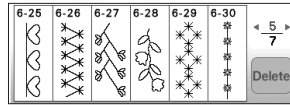
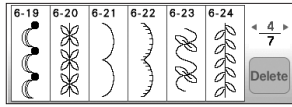
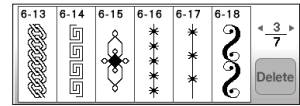
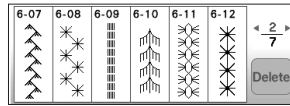
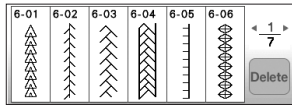

• 7-01~7-12

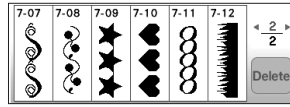
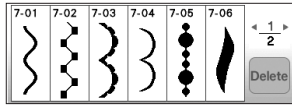

• 8-01~8-17

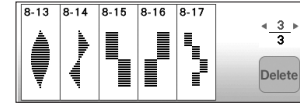
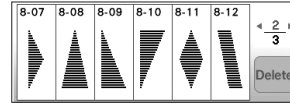
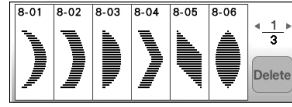

• 9-01~9-14

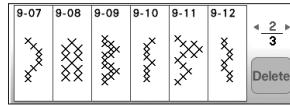
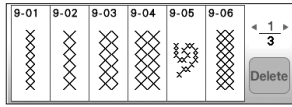

• 10-01~10-58

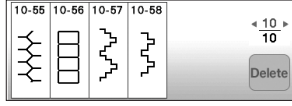
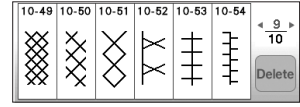
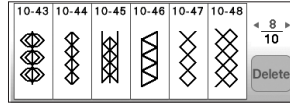
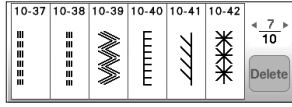
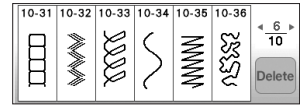
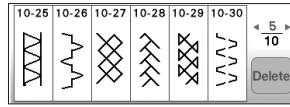
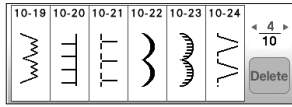
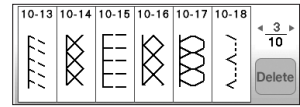
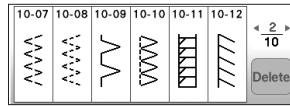
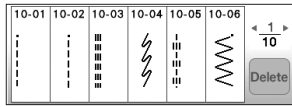

◆ Character stitches
◆ Punti a caratteri

◆ Buchstabenstiche
◆ Puntadas de carácter

◆ Points de caractères
◆ Pontos de caracteres

◆ Lettersteken
◆ Символьные строчки

A.33a ▶ AB

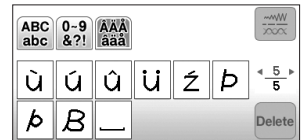
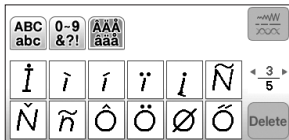
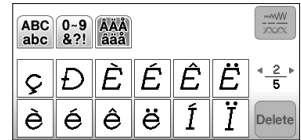
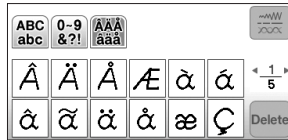
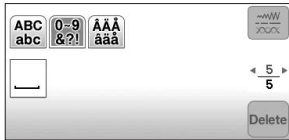
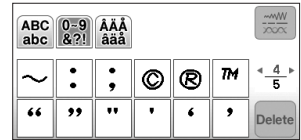
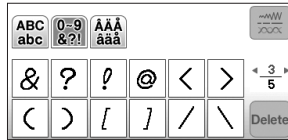
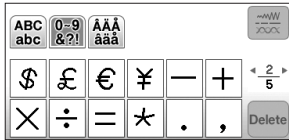
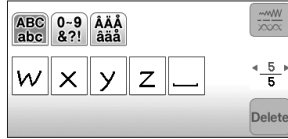
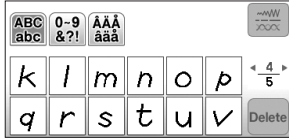
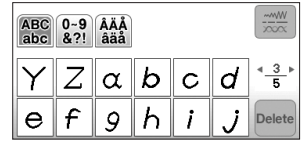
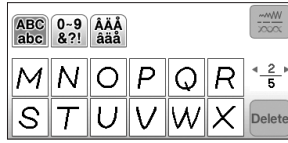
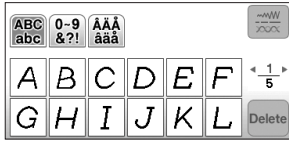

A.33a ▶ AB

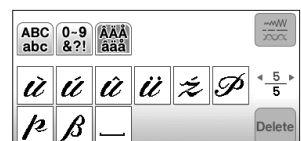
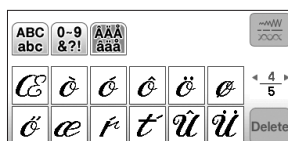
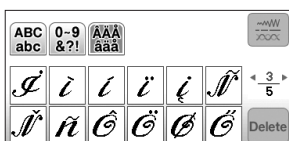
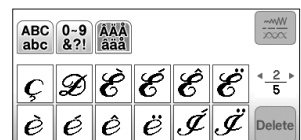
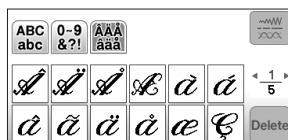
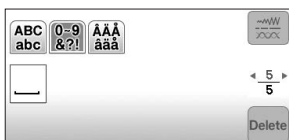
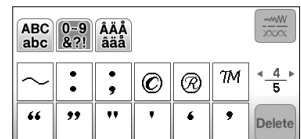
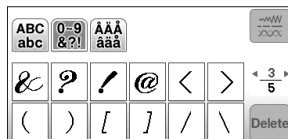
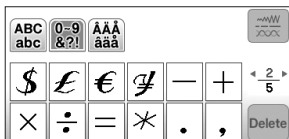
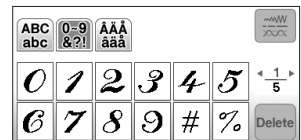
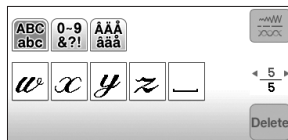
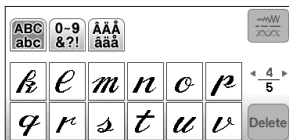
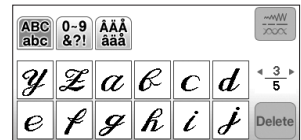
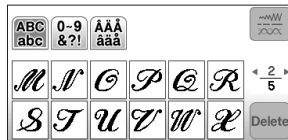
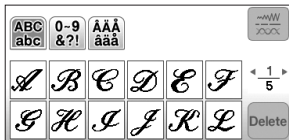

A.3.3 AB

ABC 0-9 AAA
abc &?! áää

| | | | | | | |
|---|---|---|---|---|---|---------|
| A | B | C | D | E | F | ← 1/5 → |
| G | H | I | J | K | L | Delete |

ABC 0-9 AAA
abc &?! áää

| | | | | | | |
|---|---|---|---|---|---|---------|
| M | N | O | P | Q | R | ← 2/5 → |
| S | T | U | V | W | X | Delete |

ABC 0-9 AAA
abc &?! áää

| | | | | | | |
|---|---|---|---|---|---|---------|
| Y | Z | a | b | c | d | ← 3/5 → |
| e | f | g | h | i | j | Delete |

ABC 0-9 AAA
abc &?! áää

| | | | | | | |
|---|---|---|---|---|---|---------|
| k | l | m | n | o | p | ← 4/5 → |
| q | r | s | t | u | v | Delete |

ABC 0-9 AAA
abc &?! áää

| | | | | | |
|--------|---|---|---|---|---------|
| w | x | y | z | _ | ← 5/5 → |
| Delete | | | | | |

ABC 0-9 AAA
abc &?! áää

| | | | | | | |
|---|---|---|---|---|---|---------|
| 0 | 1 | 2 | 3 | 4 | 5 | ← 1/5 → |
| 6 | 7 | 8 | 9 | # | % | Delete |

ABC 0-9 AAA
abc &?! áää

| | | | | | | |
|---|---|---|---|---|---|---------|
| § | € | ¢ | ¥ | ¤ | + | ← 2/5 → |
| × | ÷ | ≡ | ✳ | ° | , | Delete |

ABC 0-9 AAA
abc &?! áää

| | | | | | | |
|---|---|---|---|---|---|---------|
| & | ? | ! | ⊙ | < | > | ← 3/5 → |
| (|) | [|] | / | \ | Delete |

ABC 0-9 AAA
abc &?! áää

| | | | | | | |
|---|----|----|---|---|---|---------|
| ~ | ° | º | ⊙ | ⊚ | ™ | ← 4/5 → |
| ø | ºº | ºº | º | ø | º | Delete |

ABC 0-9 AAA
abc &?! áää

| | |
|--------|---------|
| _ | ← 5/5 → |
| Delete | |

ABC 0-9 AAA
abc &?! áää

| | | | | | | |
|---|---|---|---|---|---|---------|
| À | Ä | Å | Æ | à | á | ← 1/5 → |
| â | ã | ä | å | æ | ç | Delete |

ABC 0-9 AAA
abc &?! áää

| | | | | | | |
|---|---|---|---|---|---|---------|
| ç | Ð | È | É | Ê | Ë | ← 2/5 → |
| è | é | ê | ë | í | ï | Delete |

ABC 0-9 AAA
abc &?! áää

| | | | | | | |
|---|---|----|----|----|---|---------|
| İ | ı | ı̇ | ı̈ | ı̉ | Ñ | ← 3/5 → |
| Ñ | ñ | Ö | ö | Ø | Ó | Delete |

ABC 0-9 AAA
abc &?! áää

| | | | | | | |
|---|---|---|---|---|---|---------|
| œ | ò | ó | ô | õ | ø | ← 4/5 → |
| ó | œ | ř | ť | Ů | ů | Delete |

ABC 0-9 AAA
abc &?! áää

| | | | | | | |
|---|---|---|--------|---|---|---------|
| ù | ú | û | ü | z | Ɔ | ← 5/5 → |
| Ɔ | Ɔ | _ | Delete | | | |

A.3.3 AB

АБВ абв 0-9
&?! &?!

| | | | | | | |
|---|---|---|---|---|---|---------|
| А | Б | В | Г | Д | Е | ← 1/4 → |
| Ё | Ж | З | И | Й | К | Delete |

АБВ абв 0-9
&?! &?!

| | | | | | | |
|---|---|---|---|---|---|---------|
| Л | М | Н | О | П | Р | ← 2/4 → |
| С | Т | У | Ф | Х | Ц | Delete |

АБВ абв 0-9
&?! &?!

| | | | | | | |
|---|---|---|---|---|---|---------|
| Ч | Ш | Щ | Ь | Ы | Ъ | ← 3/4 → |
| Э | Ю | Я | Г | Е | І | Delete |

АБВ абв 0-9
&?! &?!

| | | | | | | |
|---|---|---|---|---|----|---------|
| İ | ÿ | ħ | ĥ | Ј | Ј̇ | ← 4/4 → |
| Ь | Ц | Ѓ | Ѕ | Ќ | _ | Delete |

АБВ абв 0-9
&?! &?!

| | | | | | | |
|---|---|---|---|---|---|---------|
| а | б | в | г | д | е | ← 1/4 → |
| ё | ж | з | и | й | к | Delete |

АБВ абв 0-9
&?! &?!

| | | | | | | |
|---|---|---|---|---|---|---------|
| л | м | н | о | п | р | ← 2/4 → |
| с | т | у | ф | х | ц | Delete |

АБВ абв 0-9
&?! &?!

| | | | | | | |
|---|---|---|---|---|---|---------|
| ч | ш | щ | ь | ы | ъ | ← 3/4 → |
| э | ю | я | г | е | і | Delete |

АБВ абв 0-9
&?! &?!

| | | | | | | |
|----|---|---|---|---|----|---------|
| ı̇ | ÿ | ħ | ĥ | Ј | Ј̇ | ← 4/4 → |
| Ь | Ц | Ѓ | Ѕ | Ќ | _ | Delete |

АБВ абв 0-9
&?! &?!

| | | | | | | |
|---|---|---|---|---|---|---------|
| 0 | 1 | 2 | 3 | 4 | 5 | ← 1/2 → |
| 6 | 7 | 8 | 9 | - | . | Delete |

АБВ абв 0-9
&?! &?!

| | | | | | | |
|---|---|---|--------|---|---|---------|
| , | & | ? | ! | (|) | ← 2/2 → |
| / | ' | _ | Delete | | | |

Katakana characters: One of the Japanese character sets.
 Katakana-Zeichen: Einer der japanischen Zeichensätze.
 Caractères Katakana : Un des ensembles de caractères japonais.
 Catalaan-tekens: Een van de Japanse tekensets.
 Caratteri Katakana: Uno dei set di caratteri giapponesi.
 Caracteres Katakana: Uno de los diferentes conjuntos de caracteres japoneses.
 Caracteres Katakana: Um dos conjuntos de caracteres japoneses.
 Катакана: Один из японских алфавитов.

Hiragana characters: One of the Japanese character sets.
 Hiragana-Zeichen: Einer der japanischen Zeichensätze.
 Caractères Hiragana : Un des ensembles de caractères japonais.
 Hiragana-tekens: Een van de Japanse tekensets.
 Caratteri Hiragana: Uno dei set di caratteri giapponesi.
 Caracteres Hiragana: Uno de los diferentes conjuntos de caracteres japoneses.
 Caracteres Hiragana: Um dos conjuntos de caracteres japoneses.
 Хирагана: Один из японских алфавитов.

Arabic numerals, Japanese Kanji numerals
 Arabische Ziffern, japanische Kanji-Ziffern
 Chiffres arabes, chiffres Kanji japonais
 Arabische cijfers, Japanse Kanji-cijfers
 Numeri arabi, numeri Kanji giapponesi
 Números arábigos, números Kanji japoneses
 Numerais arábicos, numerais japoneses em Kanji
 Арабские цифры и японские иероглифы-цифры

Kanji characters: Often used in daily life / symbols.
 Kanji-Zeichen: Im Alltag häufig verwendet / Symbole.
 Caractères Kanji : souvent utilisés dans la vie de tous les jours/symboles.
 Kanji-tekens: vaak gebruikt in het dagelijks leven/symbolen.
 Caratteri Kanji: usati spesso nella vita quotidiana/nei simboli.
 Caracteres Kanji: se utilizan a menudo cotidianamente / como símbolos.
 Caracteres Kanji: usados com frequência no dia a dia / símbolos.
 Иероглифы кандзи: часто используются в повседневной жизни или как символы.



Horizontal
 Horizontal
 Horizontal
 Horizontal
 Orizontaal
 Horizontal
 Horizontal
 По горизонтали

Vertical
 Vertikal
 Vertical
 Verticaal
 Verticale
 Vertical
 По вертикали

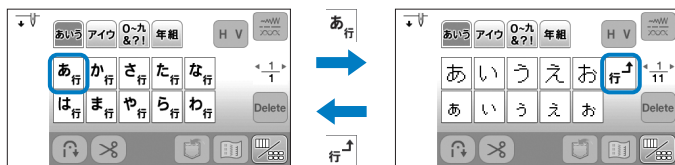

あ行

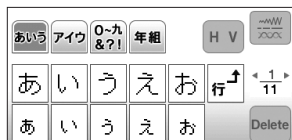

か行

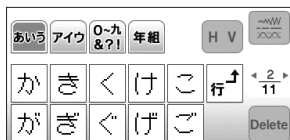

さ行



た行

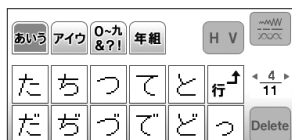

な行



は行

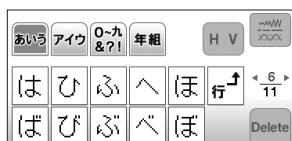

ま行



や行



ら行

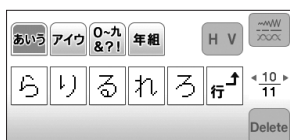

わ行



あいう アイウ 0-9 &?! 年組 H V ~nw ~sw

| | | | | |
|---|---|---|---|---|
| ア | カ | サ | タ | ナ |
| ハ | マ | ヤ | ラ | ワ |

Delete

ア行

あいう アイウ 0-9 &?! 年組 H V ~nw ~sw

| | | | | | |
|---|---|---|---|---|---|
| ア | イ | ウ | エ | オ | 行 |
| ア | イ | ウ | エ | オ | ヴ |

Delete

ア行

あいう アイウ 0-9 &?! 年組 H V ~nw ~sw

| | | | | | |
|---|---|---|---|---|---|
| ア | イ | ウ | エ | オ | 行 |
| ア | イ | ウ | エ | オ | ヴ |

Delete

カ行

あいう アイウ 0-9 &?! 年組 H V ~nw ~sw

| | | | | | |
|---|---|---|---|---|---|
| カ | キ | ク | ケ | コ | 行 |
| ガ | ギ | グ | ゲ | ゴ | |

Delete

サ行

あいう アイウ 0-9 &?! 年組 H V ~nw ~sw

| | | | | | |
|---|---|---|---|---|---|
| サ | シ | ス | セ | ソ | 行 |
| ザ | ジ | ズ | ゼ | ゾ | |

Delete

タ行

あいう アイウ 0-9 &?! 年組 H V ~nw ~sw

| | | | | | |
|---|---|---|---|---|---|
| タ | チ | ツ | テ | ト | 行 |
| ダ | ヂ | ヅ | デ | ド | ッ |

Delete

ナ行

あいう アイウ 0-9 &?! 年組 H V ~nw ~sw

| | | | | | |
|---|---|---|---|---|---|
| ナ | ニ | ヌ | ネ | ノ | 行 |
| | | | | | |

Delete

ハ行

あいう アイウ 0-9 &?! 年組 H V ~nw ~sw

| | | | | | |
|---|---|---|---|---|---|
| ハ | ヒ | フ | ヘ | ホ | 行 |
| バ | ビ | ブ | ベ | ボ | |

Delete

あいう アイウ 0-9 &?! 年組 H V ~nw ~sw

| | | | | | |
|---|---|---|---|---|---|
| パ | ピ | プ | ペ | ポ | 行 |
| | | | | | |

Delete

マ行

あいう アイウ 0-9 &?! 年組 H V ~nw ~sw

| | | | | | |
|---|---|---|---|---|---|
| マ | ミ | ム | メ | モ | 行 |
| | | | | | |

Delete

ヤ行

あいう アイウ 0-9 &?! 年組 H V ~nw ~sw

| | | | | | |
|---|---|---|--|--|---|
| ヤ | ユ | ヨ | | | 行 |
| ヤ | ユ | ヨ | | | |

Delete

ラ行

あいう アイウ 0-9 &?! 年組 H V ~nw ~sw

| | | | | | |
|---|---|---|---|---|---|
| ラ | リ | ル | レ | ロ | 行 |
| | | | | | |

Delete

ワ行

あいう アイウ 0-9 &?! 年組 H V ~nw ~sw

| | | | | | |
|---|---|---|---|--|---|
| ワ | ヲ | ン | ー | | 行 |
| | | | | | |

Delete

あいう アイウ 0-9 &?! 年組 H V ~nw ~sw

| | | | | | | |
|---|---|---|---|---|---|---|
| 0 | 1 | 2 | 3 | 4 | 5 | 行 |
| 6 | 7 | 8 | 9 | ○ | ー | |

Delete

あいう アイウ 0-9 &?! 年組 H V ~nw ~sw

| | | | | | | |
|---|---|---|---|---|---|---|
| 二 | 三 | 四 | 五 | 六 | 七 | 行 |
| 八 | 九 | 十 | & | ? | ! | |

Delete

あいう アイウ 0-9 &?! 年組 H V ~nw ~sw

| | | | | | |
|---|---|---|---|--|---|
| (|) | - | ー | | 行 |
| | | | | | |

Delete

あいう アイウ 0-9 &?! 年組 H V ~nw ~sw

| | | | | | | |
|---|---|---|---|---|---|---|
| 生 | 年 | 月 | 日 | 才 | 保 | 行 |
| 育 | 幼 | 稚 | 園 | 小 | 中 | |

Delete

あいう アイウ 0-9 &?! 年組 H V ~nw ~sw

| | | | | | | |
|---|---|---|---|---|---|---|
| 学 | 校 | 組 | 部 | 火 | 水 | 行 |
| 木 | 金 | 土 | ー | | | |

Delete

- Example of Kanji characters in daily life
- Beispiel für alltägliche Kanji-Zeichen
- Exemple de caractères Kanji dans la vie quotidienne
- Voorbeeld van Kanji-tekenen in het dagelijks leven
- Esempio di caratteri kanji usati nella vita quotidiana
- Ejemplo de caracteres Kanji en la vida cotidiana
- Exemplo de caracteres Kanji no dia a dia
- Примеры использования иероглифов кандзи в повседневной жизни

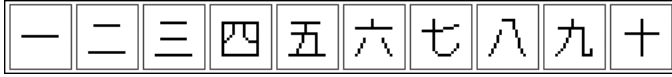

1, 2, 3, 4, 5, 6, 7, 8, 9, 10



Date of birth
Data di nascita

Geburtsdatum
Fecha de nacimiento

Date de naissance
Data de nascimento

Geboortedatum
Дата рождения

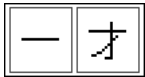

1 year old
1 anno di età

1 Jahr alt
1 año de edad

1 an
1 ano

1 jaar oud
Возраст 1 год



Nursery school
Asilo nido

Vorschule
Guardería

Crèche
Escola maternal

Peuterspeelzaal
Ясли



Kindergarten
Scuola materna

Kindergarten
Jardín de infancia

École maternelle
Jardim de infância

Kleuterschool
Детский сад



Elementary school
Scuola elementare

Grundschule
Escuela primaria

École primaire
Ensino básico

Basisschool
Начальная школа



Junior high school
Scuola superiore

Realschule
Escuela secundaria

Collège
Ensino médio

Middelbare school
Средняя школа



Group/Class
Gruppo/classe

Gruppe/Klasse
Grupo/Clase

Groupe/Classe
Grupo/Classe

Groep/klas
Группа, класс



Club/Division
Club/sezione

Club/Abteilung
Club/División

Club/Division
Clube/Divisão

Club/Divisie
Клуб, подразделение



Moon/Monday
Luna/lunedì

Mond/Montag
Luna/Lunes

Lune/Lundi
Lua/Segunda-feira

Maan/Maandag
Луна, понедельник



Fire/Tuesday
Fuoco/martedì

Feuer/Dienstag
Fuego/Martes

Feu/Mardi
Fogo/Terça-feira

Vuur/Dinsdag
Огонь, вторник



Water/Wednesday
Acqua/mercoledì

Wasser/Mittwoch
Agua/Miércoles

Eau/Mercredi
Água/Quarta-feira

Water/Woensdag
Вода, среда



Tree/Thursday
Albero/giovedì

Baum/Donnerstag
Árbol/Jueves

Arbre/Jeudi
Árvore/Quinta-feira

Boom/Donderdag
Дерево, четверг



Gold/Friday
Oro/venerdì

Gold/Freitag
Oro/Viernes

Or/Vendredi
Ouro/Sexta-feira

Goud/Vrijdag
Золото, пятница



Soil/Saturday
Terra/sabato

Erde/Samstag
Tierra/Sábado

Terre/Samedi
Terra/Sábado

Grond/Zaterdag
Земля, суббота



Sun/Sunday
Sole/domenica

Sonne/Sonntag
Sol/Domingo

Soleil/Dimanche
Sol/Domingo

Zon/Zondag
Солнце, воскресенье



January 1st (Monday)
1° gennaio (lunedì)

1. Januar (Montag)
1 de enero (lunes)

1er janvier (lundi)
1° de janeiro (Segunda-feira)

1 januari (maandag)
1 января (понедельник)

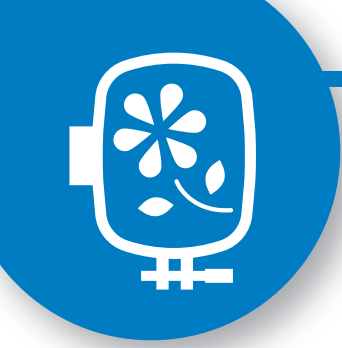

Preparing to Embroider
Vorbereitung zum Sticken
Préparation de la broderie
Vorbereidingen voor borduren
Preparativi per il ricamo
Preparativos para bordar
Preparação para bordar
Подготовка к вышиванию

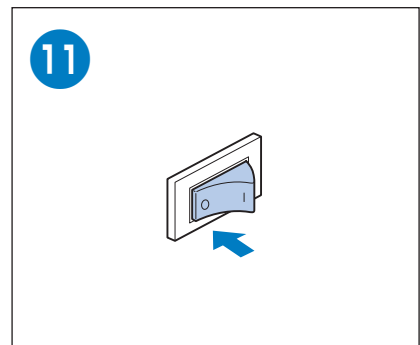
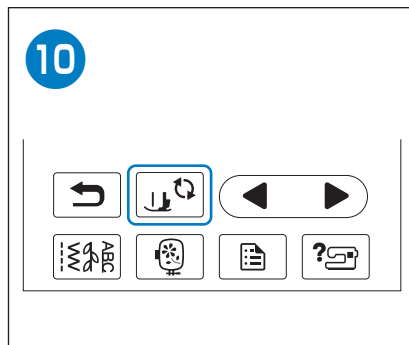
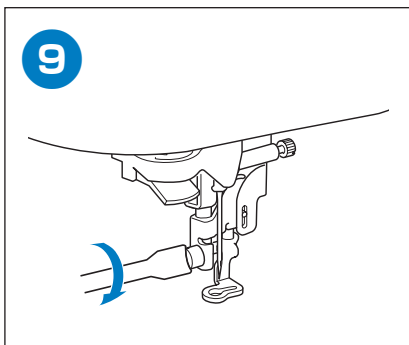
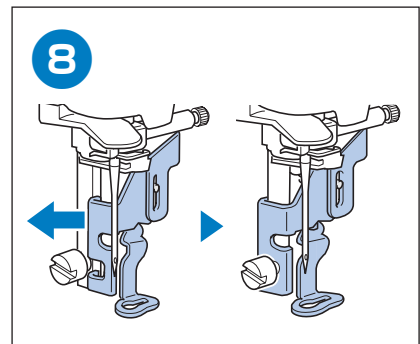
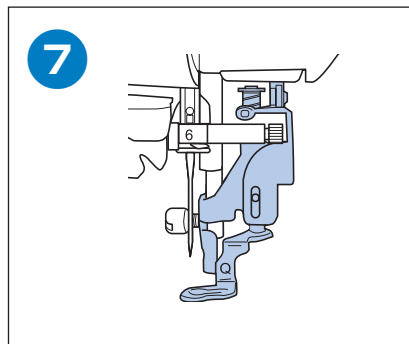
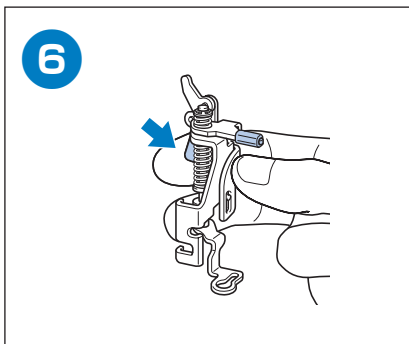
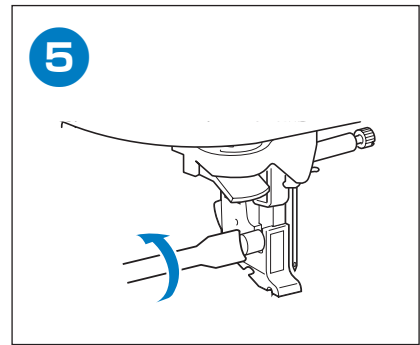
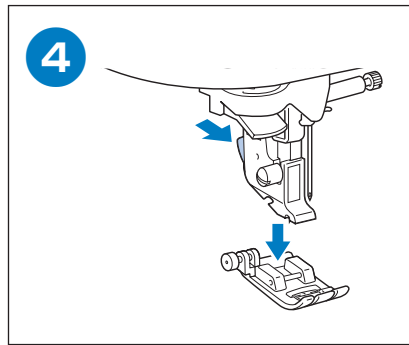
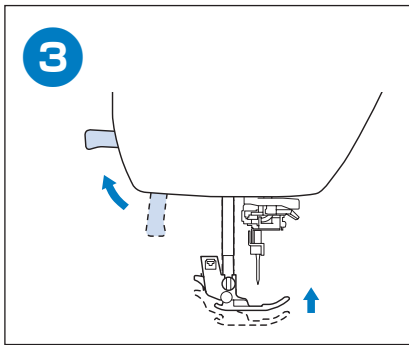
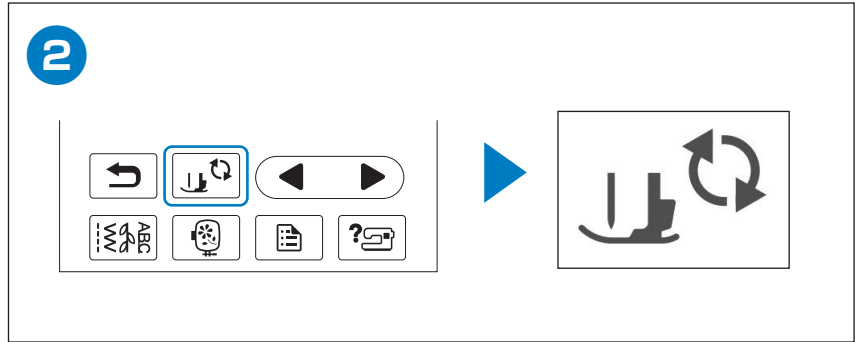
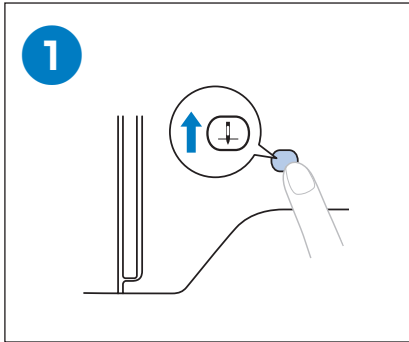

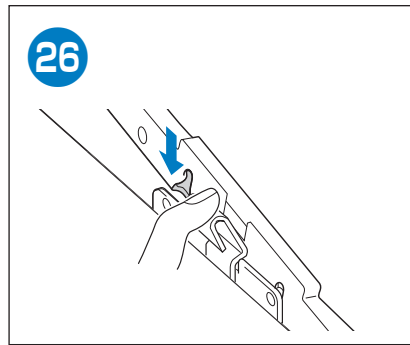
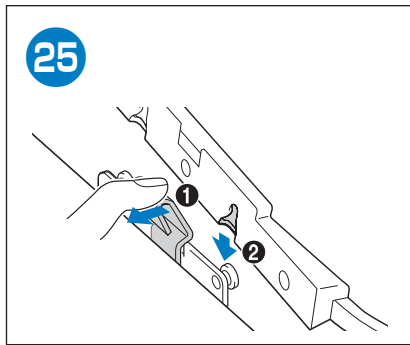
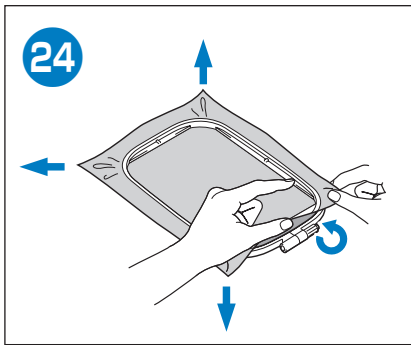
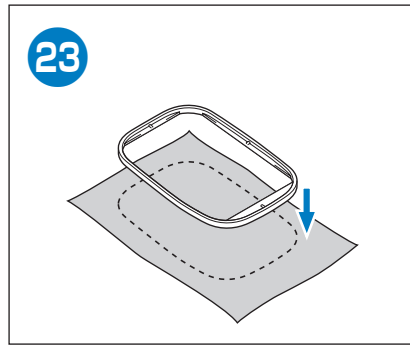
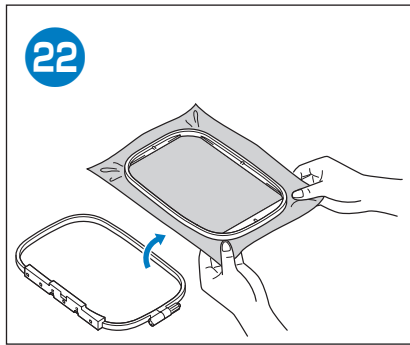
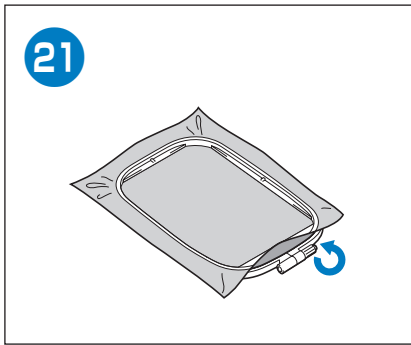
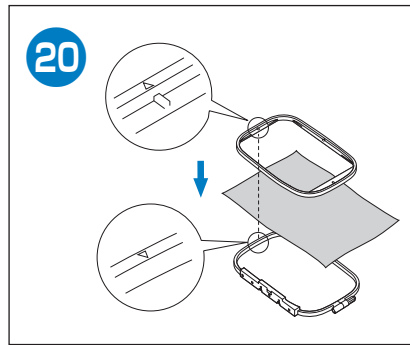
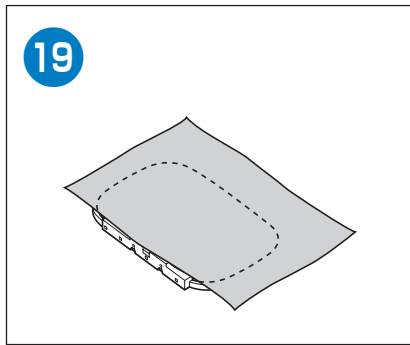
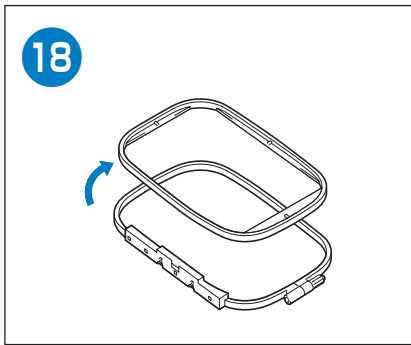
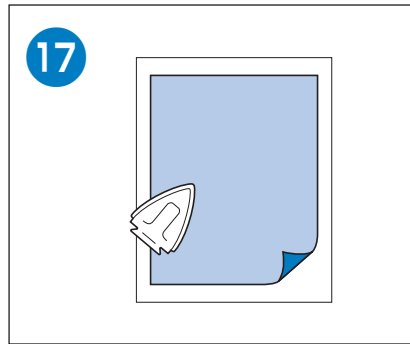
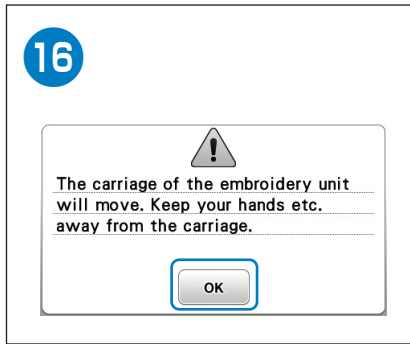
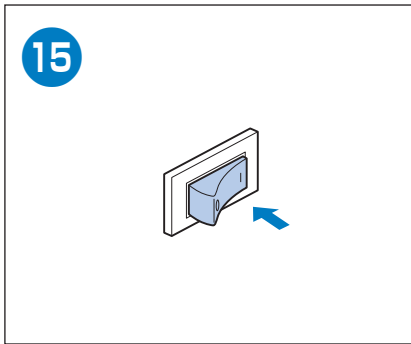
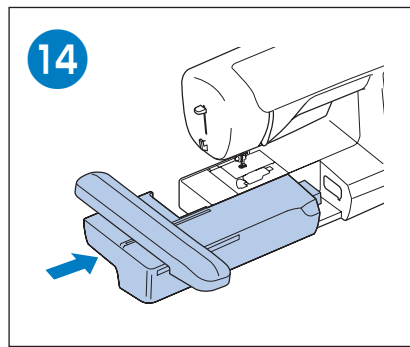
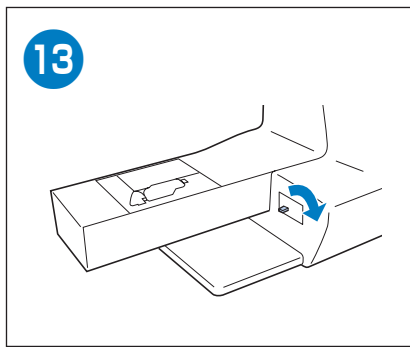
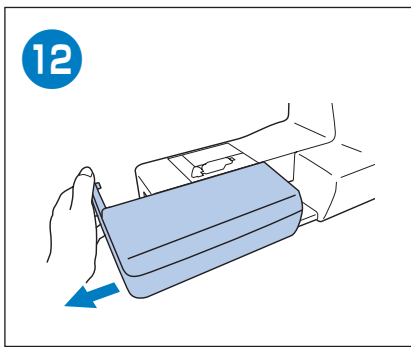



Selecting Embroidery Patterns
Auswählen von Stickmustern
Sélection des motifs de broderie
Borduurpatronen selecteren
Come selezionare i ricami
Seleccionar patrones de bordado
Seleção de padrões de bordado
Выбор рисунков для вышивания

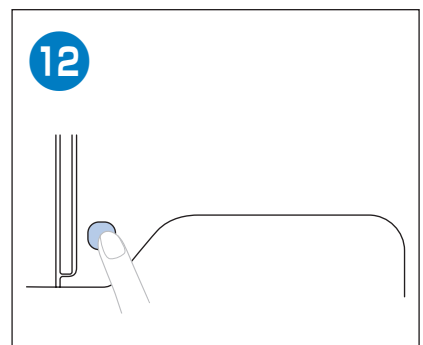
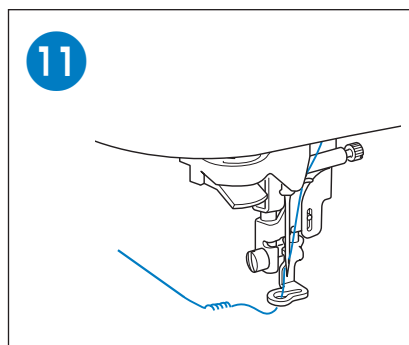
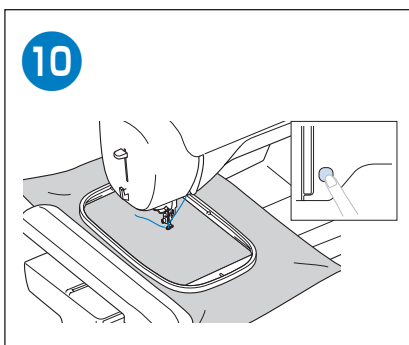
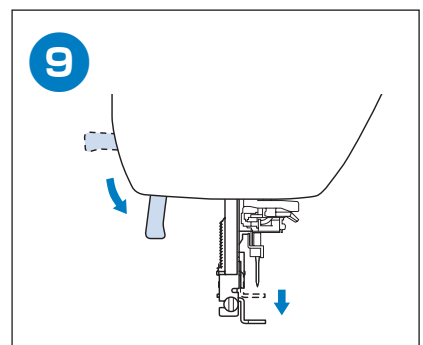
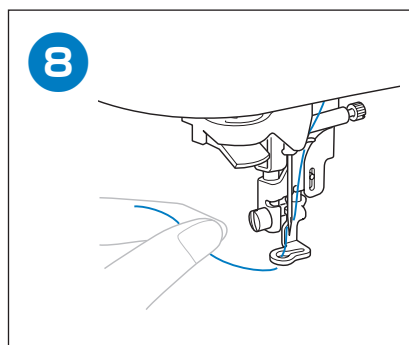
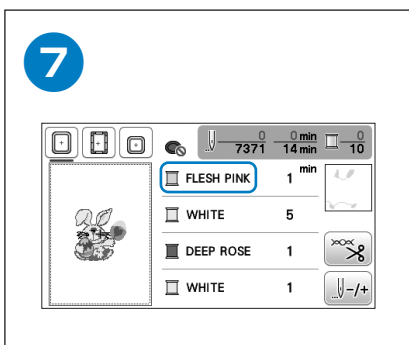
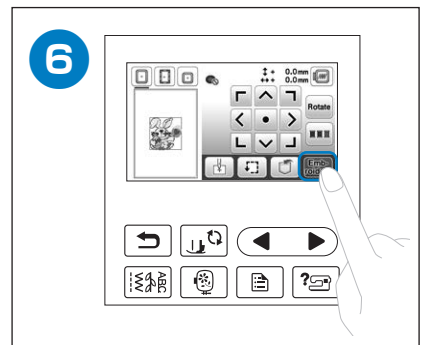
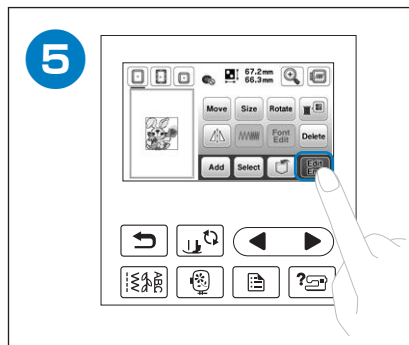
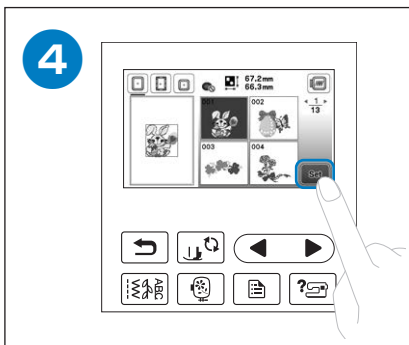
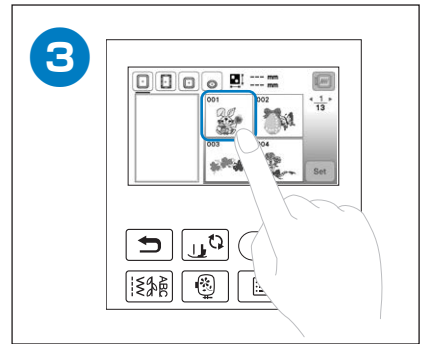
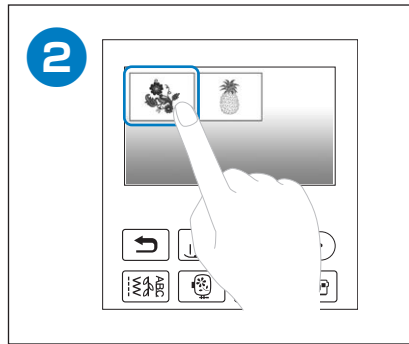
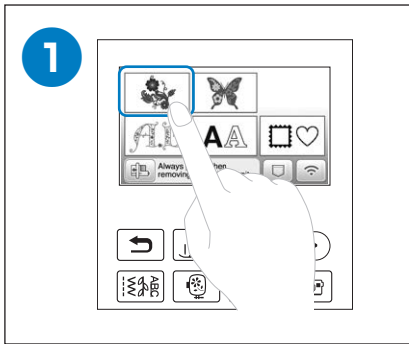

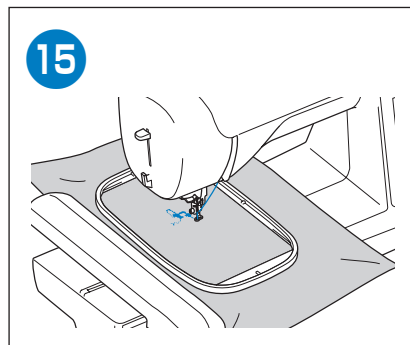
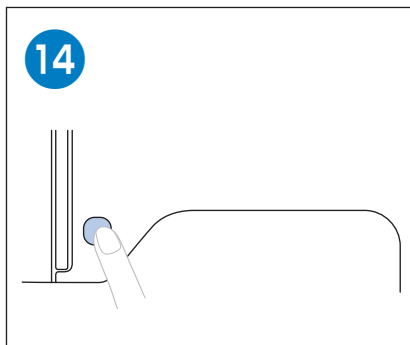
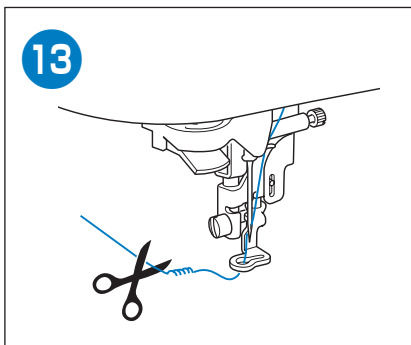



English
German
French
Dutch
Italian
Spanish
Portuguese-BR
Russian
888-L11/L12/K10



D029M2-001